



*Fabricated fittings reduce head losses in the system.*

# Hydraulics of Storm Sewers

89

## CHAPTER 4

Storm sewers may be designed as either open channels, where there is a free water surface, or for pressure or “pipe” flow under surcharged conditions. When the storm sewer system is to be designed as pressure flow it should be assured that the hydraulic grade line does not exceed the floor level of any adjacent basements where surcharge conditions may create unacceptable flooding or structural damages.

Regardless of whether the sewer system is to be designed as an open channel or pressure system, a thorough hydraulic analysis should be performed to assure that the system operates efficiently. Too often in the past a simplistic approach to the design of storm sewers was taken, with the design and the sizing of the conduits and appurtenances derived from nomographs or basic hydraulic flow equations.

As a result of this, excessive surcharging has been experienced in many instances due to improper design of the hydraulic structures. This in turn has led to flooding damage, both surface and structural, when service connections have been made to the storm sewer. Overloading of the sewer system may occur in upper reaches while lower segments may be flowing well below capacity because of the inability of the upper reaches to transport the flow or vice versa with downstream surcharging creating problems.

In conclusion, an efficient, cost effective storm system cannot be designed without a complete and proper hydraulic analysis.

The following section outlines the basic hydraulic principles for open channel and conduit flow. Subsequent sections of this chapter deal with losses (friction and form) within the sewer system and the hydraulics of storm water inlets. Manual calculations for designing a storm drainage system are presented in Chapter 5. An overview of several commonly used computer programs which may be used to design sewer systems is also given in Chapter 5.



*CSP is easy to install in difficult trench conditions.*

**CLASSIFICATION OF CHANNEL FLOW**

Channel flow is distinguished from closed-conduit or pipe flow by the fact that the cross-section of flow is not dependent solely on the geometry of the conduit, but depends also on the free surface (or depth) which varies with respect to space and time and is a function of discharge. As a result, various categories of flow can be identified:

**STEADY** flow exhibits characteristics at a point which is constant with respect to time. Flow subject to very slow change may be assumed to be steady with little error.

**UNSTEADY** flow results when some time-dependent boundary condition—tide, floodwave or gate movement causes a change in flow and/or depth to be propagated through the system.

**UNIFORM** flow, strictly speaking, is flow in which velocity is the same in magnitude and direction at every point in the conduit. Less rigidly, uniform flow is assumed to occur when the velocity at corresponding points in the cross-section is the same along the length of the channel. Note that uniform flow is possible only if:

- flow is steady, or nearly so
- the channel is prismatic (i.e., has the same cross-sectional shape at all sections)
- depth is constant along the length of the channel
- the bedslope is equal to the energy gradient.

**NON-UNIFORM** or **VARIED** flow occurs when any of the requirements for uniform flow are not satisfied. Varied flow may be further sub-classified depending on the abruptness of the variation.

**GRADUALLY VARIED** flow occurs when depth changes occur over long distances such as the flow profiles or backwater profiles which occur between distinct reaches of uniform flow.

**RAPIDLY VARIED** flow occurs in the vicinity of transitions caused by relatively abrupt changes in channel geometry or where a hydraulic jump occurs.

Figure 4.1 illustrates various typical occurrences of these different classes of flow. In the design of sewer systems the flow, except where backwater or surcharging may occur, is generally assumed to be steady and uniform.

**Laws of Conservation**

Fluid mechanics is based on the law of conservation applied to the mass, energy and momentum of a fluid in motion. Full details can be found in any text on the subject. At this point, it is sufficient to note that:

- 1) Conservation of mass reduces to a simple statement of continuity for fluids in which the density is essentially constant.
- 2) Conservation of energy is usually stated as the Bernoulli equation which is discussed below.
- 3) Conservation of momentum is significant in transitions where there are local and significant losses of energy, such as across a hydraulic jump.

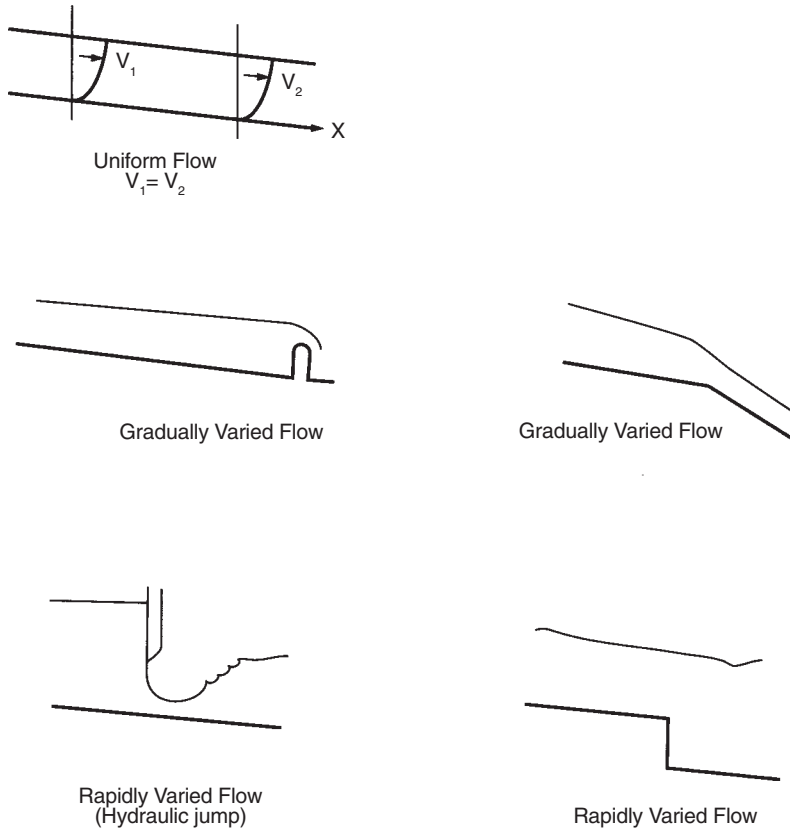

**Figure 4.1** Different classes of open channel flow

### Bernoulli Equation

The law of conservation of energy as expressed by the Bernoulli Equation is the basic principle most often used in hydraulics. This equation may be applied to any conduit with a constant discharge. All the friction flow formulae such as the Manning's, Cutter, Hazer-William's, etc., have been developed to express the rate of energy dissipation as it applies to the Bernoulli Equation. The theorem states that the energy head at any cross-section must equal that in any other downstream section plus the intervening losses.<sup>1</sup>

In open channels the flow is primarily controlled by the gravitational action on moving fluid, which overcomes the hydraulic energy losses. The Bernoulli Equation defines the hydraulic principles involved in open channel flow.

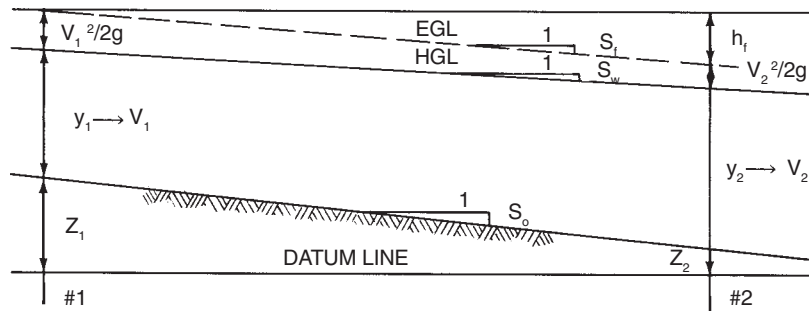

Figure 4.2 Energy in open channel flow

$$H = y + \frac{V^2}{2g} + Z + h_f$$

- |                                  |                            |
|----------------------------------|----------------------------|
| H = Total Velocity Head          | $h_f$ = Headloss           |
| y = Water Depth                  | V = Mean Velocity          |
| $\frac{V^2}{2g}$ = Velocity Head | Z = Height above Datum     |
| EGL = Energy Grade Line          | HGL = Hydraulic Grade Line |
| $S_o$ = Slope of Bottom          | $S_f$ = Slope of EGL       |
|                                  | $S_w$ = Slope of HGL       |

The total energy at point #1 is equal to the total energy at point #2 thus

$$y_1 + Z_1 + \frac{V_1^2}{2g} = y_2 + Z_2 + \frac{V_2^2}{2g} + h_f$$

For pressure or closed conduit flow, the Bernoulli Equation can be written as:

$$\frac{V_1^2}{2g} + \frac{P_1}{\gamma} + Z_1 = \frac{V_2^2}{2g} + \frac{P_2}{\gamma} + Z_2 + h_f$$

Where P = pressure at given location  
 $\gamma$  = specific weight of fluid

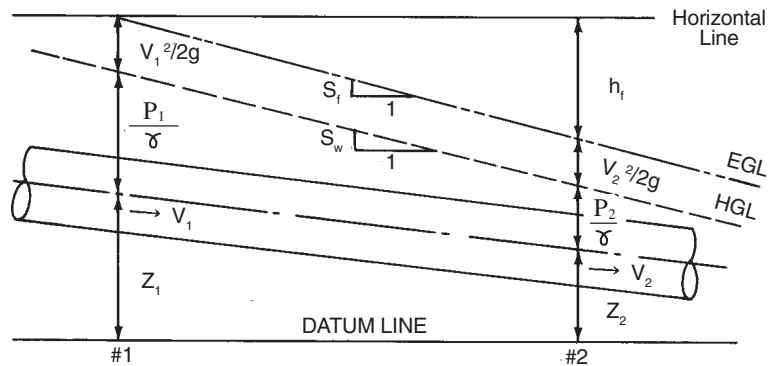

Figure 4.3 Energy in closed conduit flow

**SPECIFIC ENERGY**

An understanding of open channel flow is aided by the concept of Specific Energy  $E$ , which is simply the total energy when the channel bottom is taken to be the datum. Thus:

$$E = y + V^2/2g = y + Q^2/2gA^2$$

Figure 4.4 shows a plot of specific energy as a function of depth of flow for a known cross-sectional shape and constant discharge  $Q$ . The turning value occurs where  $E$  is a minimum and defines the critical depth  $y_{cr}$ . The critical depth is defined by setting  $dE/dy = 0$  from which it can be shown that:

$$\frac{Q^2 T}{gA^3} = 1$$

in which the surface breadth,  $T$  and cross-sectional area,  $A$  are functions of the depth,  $y$ . The velocity corresponding to  $y_{cr}$  is called the critical velocity and is given by:

$$\frac{V_{cr}^2 T}{gA} = 1$$

or  $V_{cr} = (g A/T)^{1/2}$

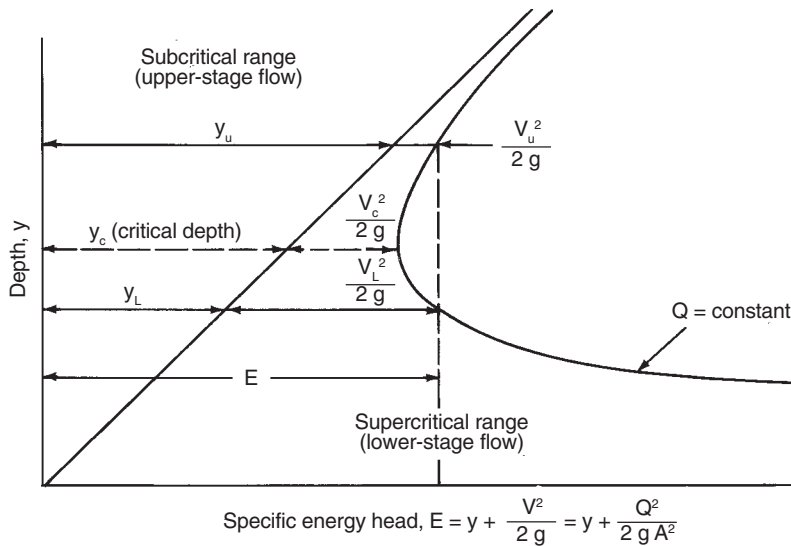

**Figure 4.4** Typical plot of specific energy as a function of depth

For the special case of rectangular cross-sections,  $A = B \cdot y$  and  $T = B$ , where  $B$  is the basewidth. In this case the above equation for critical depth reduces to:

$$\frac{Q^2}{g \cdot B^3 \cdot y^2} = 1$$

from which the critical depth is found as  $y_{cr} = (Q^2/gB^2)^{1/3}$  and the corresponding critical velocity is  $V_{cr} = (g \cdot y)^{1/2}$ .

The critical depth serves to distinguish two more classes of open channel flow:

- $y > y_{cr}$  The specific energy is predominantly potential energy ( $y$ ), the kinetic energy is small and the velocity is less than  $V_{cr}$ . The flow is called SUBCRITICAL (i.e., with respect to velocity) or TRANQUIL.
- $y < y_{cr}$  Most of the specific energy is kinetic energy and the depth or potential energy is small. The velocity is greater than  $V_{cr}$  and the flow is therefore called SUPERCRITICAL or RAPID.

For circular conduits Figure 4.5 provides a nomograph for calculating  $y_{cr}$ .

For pipe arch CSP, pipe charts provide a graphical method of determining critical flow depths (Figures 4.6, 4.7).

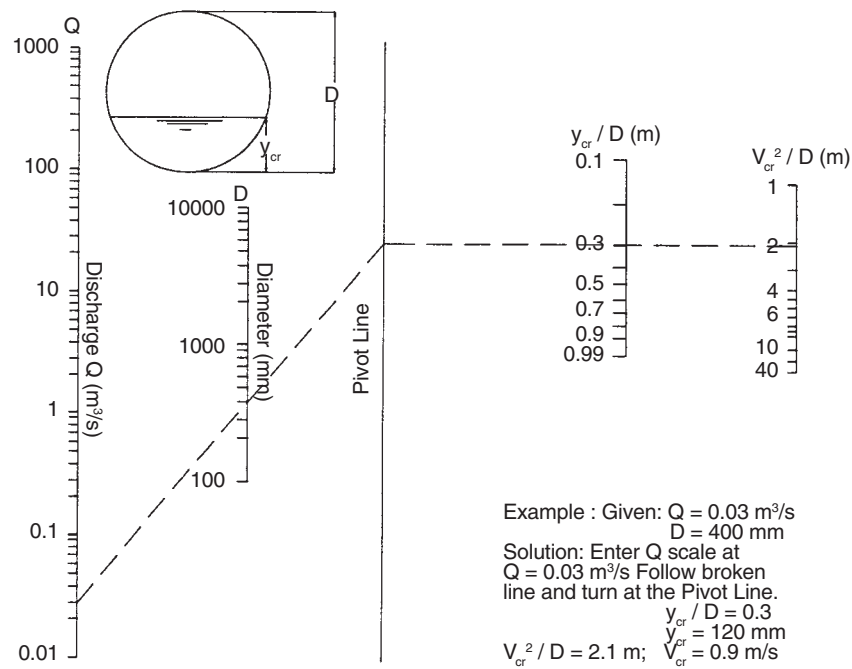

Figure 4.5 Critical flow and critical velocity in circular conduits



**ENERGY LOSSES**

When using the Bernoulli Equation for hydraulic design it is necessary to make allowance for energy losses as illustrated in Figure 4.2. The losses are expressed in terms of head and may be classified as:

*friction losses*—these are due to the shear stress between the moving fluid and the boundary material.

*form losses*—these are caused by abrupt transitions resulting from the geometry of manholes, bends, expansions and contractions.

It is a common mistake to include only friction losses in the hydraulic analysis. Form losses can constitute a major portion of the total head loss and, although estimates of form losses are generally based on empirical equations, it is important to make allowance for them in the design.



*Proper installation techniques are always important.*



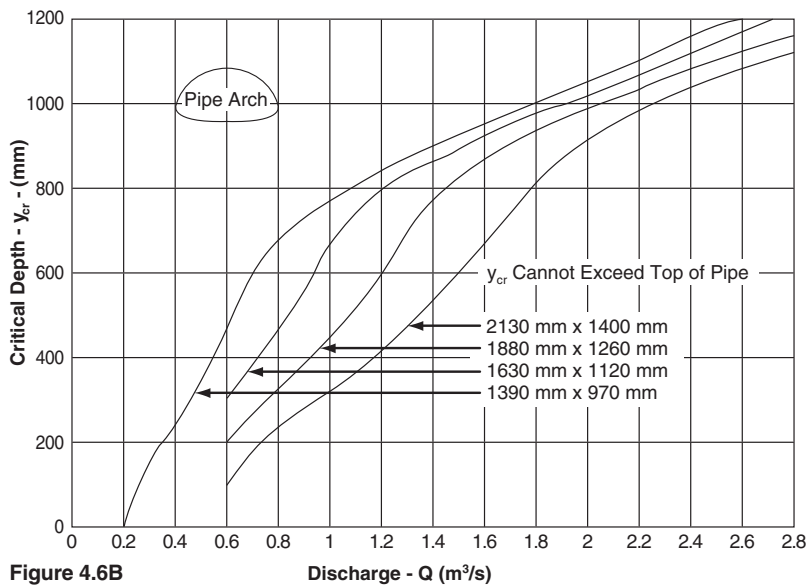
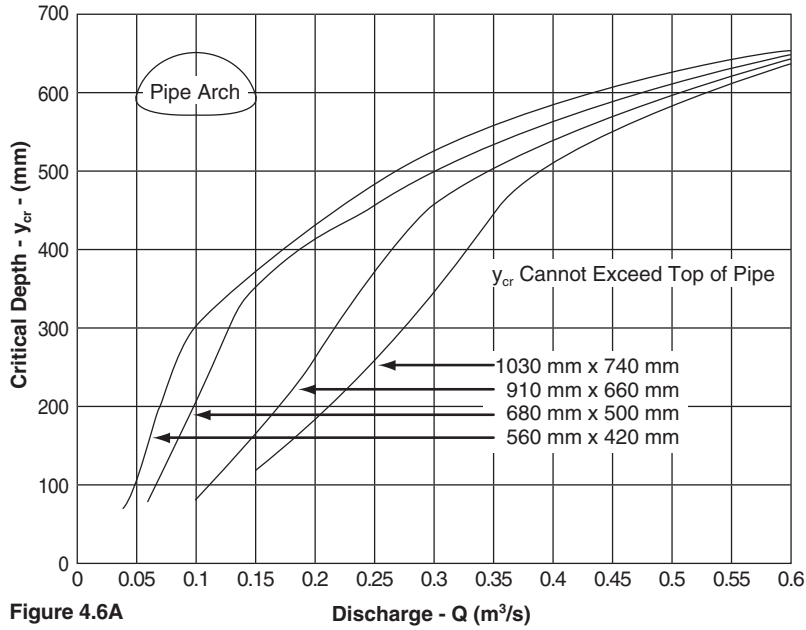

Bureau of Public Roads  
 Jan. 1964  
 Federal Highway Administration<sup>2</sup>

CRITICAL DEPTH  
 STANDARD C.S. PIPE-ARCH

Figure 4.6 Critical depth curves for standard corrugated steel pipe

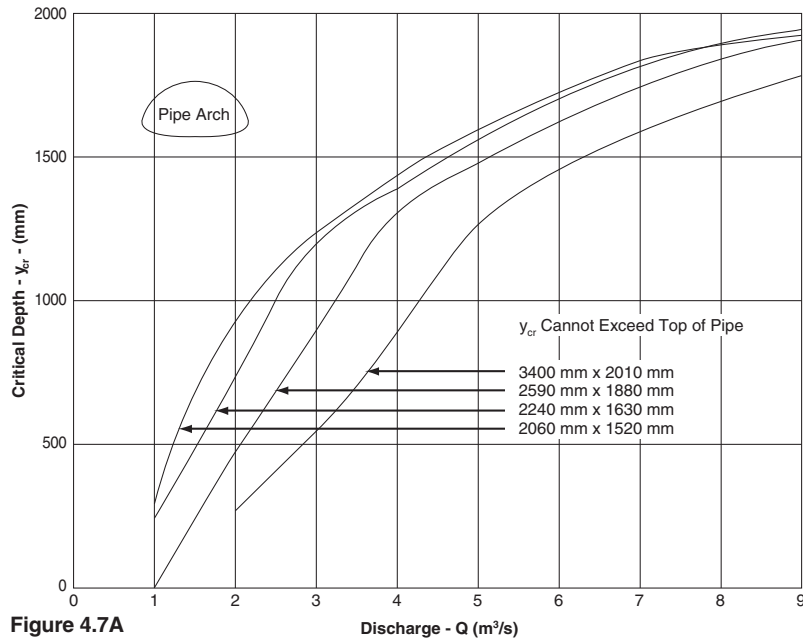

Figure 4.7A

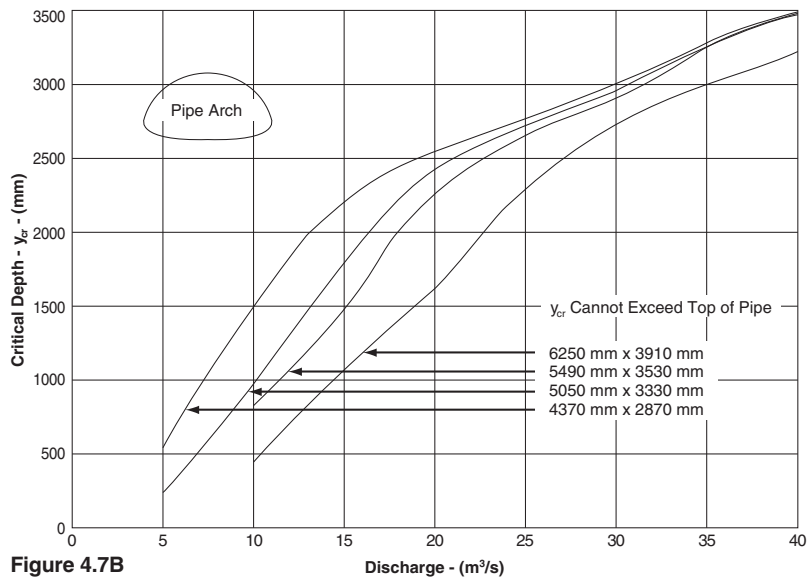

Figure 4.7B

Bureau of Public Roads  
 Jan. 1964  
 Federal Highway Administration<sup>2</sup>

CRITICAL DEPTH  
 STRUCTURAL PLATE  
 C.S. PIPE-ARCH

Figure 4.7 Critical depth curves for structural plate pipe-arch

**Table 4.1** Waterway areas for standard sizes of corrugated steel conduits

| Round Pipe                       |                           | Pipe-Arch<br>(25mm Corrugation) |                           | Structural<br>Plate Arch |                           |
|----------------------------------|---------------------------|---------------------------------|---------------------------|--------------------------|---------------------------|
| Diameter<br>(mm)                 | Area<br>(m <sup>2</sup> ) | Size<br>(mm)                    | Area<br>(m <sup>2</sup> ) | Size<br>(mm)             | Area<br>(m <sup>2</sup> ) |
| 300                              | 0.07                      | 1330 x 1030                     | 1.09                      | 1520 x 810               | 0.98                      |
| 400                              | 0.13                      | 1550 x 1200                     | 1.48                      | 1830 x 840               | 1.16                      |
| 500                              | 0.2                       | 1780 x 1360                     | 1.93                      | 1830 x 970               | 1.39                      |
| 600                              | 0.28                      | 2010 x 1530                     | 2.44                      | 2130 x 860               | 1.39                      |
| 700                              | 0.39                      |                                 |                           | 2130 x 1120              | 1.86                      |
| 800                              | 0.5                       |                                 |                           | 2440 x 1020              | 1.86                      |
| 900                              | 0.64                      |                                 |                           | 2440 x 1270              | 2.42                      |
| 1000                             | 0.79                      |                                 |                           | 2740 x 1180              | 2.46                      |
| 1200                             | 1.13                      |                                 |                           | 2740 x 1440              | 3.07                      |
| 1400                             | 1.54                      |                                 |                           | 3050 x 1350              | 3.16                      |
| 1600                             | 2.01                      |                                 |                           | 3050 x 1600              | 3.81                      |
| 1800                             | 2.54                      |                                 |                           | 3350 x 1360              | 3.44                      |
| 2000                             | 3.14                      |                                 |                           | 3350 x 1750              | 4.65                      |
| Pipe-Arch<br>(13 mm Corrugation) |                           | Structural Plate Pipe-Arch      |                           | 3660 x 1520              | 4.18                      |
|                                  |                           |                                 |                           | 3660 x 1910              | 5.48                      |
| Size<br>(mm)                     |                           | Area<br>(m <sup>2</sup> )       |                           | 3960 x 1680              | 5.02                      |
|                                  |                           |                                 |                           | 3960 x 2060              | 6.5                       |
| 450 x 340                        |                           | 0.11                            |                           | 4270 x 1840              | 5.95                      |
|                                  |                           |                                 |                           | 4270 x 2210              | 7.43                      |
| 560 x 420                        |                           | 0.19                            |                           | 4570 x 1870              | 6.41                      |
|                                  |                           |                                 |                           | 4570 x 2360              | 8.55                      |
| 680 x 500                        |                           | 0.27                            |                           | 4880 x 2030              | 7.43                      |
|                                  |                           |                                 |                           | 4880 x 2520              | 9.75                      |
| 800 x 580                        |                           | 0.37                            |                           | 5180 x 2180              | 8.55                      |
|                                  |                           |                                 |                           | 5180 x 2690              | 11.06                     |
| 910 x 660                        |                           | 0.48                            |                           | 5490 x 2210              | 9.01                      |
|                                  |                           |                                 |                           | 5490 x 2720              | 11.71                     |
| 1030 x 740                       |                           | 0.61                            |                           | 5790 x 2360              | 10.22                     |
|                                  |                           |                                 |                           | 5790 x 2880              | 13.01                     |
| 1150 x 820                       |                           | 0.74                            |                           | 6100 x 2530              | 11.52                     |
|                                  |                           |                                 |                           | 6100 x 3050              | 14.59                     |
| 1390 x 970                       |                           | 1.06                            |                           |                          |                           |
|                                  |                           |                                 |                           |                          |                           |
| 1630 x 1120                      |                           | 1.44                            |                           |                          |                           |
|                                  |                           |                                 |                           |                          |                           |
| 1880 x 1260                      |                           | 1.87                            |                           |                          |                           |
|                                  |                           |                                 |                           |                          |                           |
| 2130 x 1400                      |                           | 2.36                            |                           |                          |                           |
|                                  |                           |                                 |                           |                          |                           |
|                                  |                           | 2060 x 1520                     | 2.49                      |                          |                           |
|                                  |                           | 2240 x 1630                     | 2.9                       |                          |                           |
|                                  |                           | 2440 x 1750                     | 3.36                      |                          |                           |
|                                  |                           | 2590 x 1880                     | 3.87                      |                          |                           |
|                                  |                           | 2690 x 2080                     | 4.49                      |                          |                           |
|                                  |                           | 3100 x 1980                     | 4.83                      |                          |                           |
|                                  |                           | 3400 x 2010                     | 5.28                      |                          |                           |
|                                  |                           | 3730 x 2290                     | 6.61                      |                          |                           |
|                                  |                           | 3890 x 2690                     | 8.29                      |                          |                           |
|                                  |                           | 4370 x 2870                     | 9.76                      |                          |                           |
|                                  |                           | 4720 x 3070                     | 11.38                     |                          |                           |
|                                  |                           | 5050 x 3330                     | 13.24                     |                          |                           |
|                                  |                           | 5490 x 3530                     | 15.1                      |                          |                           |
|                                  |                           | 5890 x 3710                     | 17.07                     |                          |                           |
|                                  |                           | 6250 x 3910                     | 19.18                     |                          |                           |
|                                  |                           | 7040 x 4060                     | 22.48                     |                          |                           |
|                                  |                           | 7620 x 4240                     | 25.27                     |                          |                           |

HYDRAULIC PROPERTIES OF PIPE ARCH CONDUITS FLOWING PART FULL

**Table 4.2**  
Determination of area

| $\frac{y}{D}$ | Values of $\frac{A}{BD}$ |      |      |      |      |      |      |      |      |      |
|---------------|--------------------------|------|------|------|------|------|------|------|------|------|
|               | .00                      | .01  | .02  | .03  | .04  | .05  | .06  | .07  | .08  | .09  |
| 1             | .072                     | .081 | .090 | .100 | .109 | .119 | .128 | .138 | .148 |      |
| 2             | .157                     | .167 | .177 | .187 | .197 | .207 | .217 | .227 | .237 | .247 |
| 3             | .257                     | .267 | .277 | .287 | .297 | .307 | .316 | .326 | .336 | .346 |
| 4             | .356                     | .365 | .375 | .385 | .394 | .404 | .413 | .423 | .432 | .442 |
| 5             | .451                     | .460 | .470 | .479 | .488 | .497 | .506 | .515 | .524 | .533 |
| 6             | .541                     | .550 | .559 | .567 | .576 | .584 | .592 | .600 | .608 | .616 |
| 7             | .624                     | .632 | .640 | .647 | .655 | .662 | .670 | .677 | .684 | .690 |
| 8             | .697                     | .704 | .710 | .716 | .722 | .728 | .734 | .740 | .745 | .750 |
| 9             | .755                     | .760 | .764 | .769 | .772 | .776 | .780 | .783 | .785 | .787 |
| 1.0           | .788                     |      |      |      |      |      |      |      |      |      |

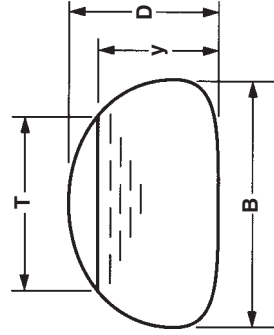

y = Depth of flow  
 D = Rise of conduit  
 B = Span of conduit  
 A = Area of flow  
 R = Hydraulic radius  
 T = Top width of flow

**Table 4.3**  
Determination of hydraulic radius

| $\frac{y}{D}$ | Values of $\frac{R}{D}$ |      |      |      |      |      |      |      |      |      |
|---------------|-------------------------|------|------|------|------|------|------|------|------|------|
|               | .00                     | .01  | .02  | .03  | .04  | .05  | .06  | .07  | .08  | .09  |
| 1             | .078                    | .086 | .094 | .102 | .110 | .118 | .126 | .133 | .141 |      |
| 2             | .148                    | .156 | .163 | .170 | .177 | .184 | .191 | .197 | .204 | .210 |
| 3             | .216                    | .222 | .228 | .234 | .240 | .245 | .250 | .256 | .261 | .266 |
| 4             | .271                    | .275 | .280 | .284 | .289 | .293 | .297 | .301 | .305 | .308 |
| 5             | .312                    | .315 | .319 | .322 | .325 | .328 | .331 | .334 | .337 | .339 |
| 6             | .342                    | .344 | .346 | .348 | .350 | .352 | .354 | .355 | .357 | .358 |
| 7             | .360                    | .361 | .362 | .363 | .364 | .364 | .364 | .365 | .365 | .365 |
| 8             | .365                    | .365 | .364 | .364 | .363 | .362 | .361 | .360 | .359 | .357 |
| 9             | .355                    | .353 | .350 | .348 | .344 | .341 | .337 | .332 | .326 | .318 |
| 1.0           | .299                    |      |      |      |      |      |      |      |      |      |

**Table 4.4**  
Determination of top width

| $\frac{y}{D}$ | Values of $\frac{T}{B}$ |      |      |      |      |      |      |      |      |      |
|---------------|-------------------------|------|------|------|------|------|------|------|------|------|
|               | .00                     | .01  | .02  | .03  | .04  | .05  | .06  | .07  | .08  | .09  |
| 1             | .900                    | .914 | .927 | .938 | .948 | .956 | .964 | .971 | .976 |      |
| 2             | .982                    | .986 | .990 | .993 | .995 | .997 | .998 | .998 | .999 | .999 |
| 3             | .997                    | .996 | .995 | .993 | .991 | .989 | .987 | .985 | .982 | .979 |
| 4             | .976                    | .971 | .967 | .964 | .960 | .956 | .951 | .947 | .942 | .937 |
| 5             | .932                    | .927 | .921 | .916 | .910 | .904 | .897 | .891 | .884 | .877 |
| 6             | .870                    | .863 | .855 | .847 | .839 | .830 | .822 | .813 | .803 | .794 |
| 7             | .784                    | .773 | .763 | .752 | .741 | .729 | .717 | .704 | .691 | .678 |
| 8             | .664                    | .649 | .634 | .618 | .602 | .585 | .567 | .548 | .528 | .508 |
| 9             | .486                    | .462 | .437 | .410 | .381 | .349 | .313 | .272 | .223 | .158 |



**FRICTION LOSSES**

In North America, the Manning and Kutter equations are commonly used to estimate the friction gradient for turbulent flow in storm sewers. In both equations fully developed rough turbulent flow is assumed so that the head loss per unit length of conduit is approximately proportional to the square of the discharge (or velocity). Both equations use an empirical coefficient 'n' to describe the roughness of the channel boundary. Tables 4.9 and 4.10 give suggested values for 'n' for various corrugation profiles and linings.

**Manning Equation**

The Manning Equation is one of a number of so-called exponential equations. It is widely used in open channel flow but can also be applied to closed conduit flow. The equation is not dimensionally homogeneous and a correction factor must be applied depending upon the system of units being used.

$$V = \frac{1}{n} R^{2/3} S_f^{1/2}$$

Where

|                |   |   |                     |
|----------------|---|---|---------------------|
| V              | = | average velocity  | (m/s)               |
| Q              | = | discharge   | (m <sup>3</sup> /s) |
| R              | = | hydraulic radius = A/P                                      | (m)                 |
| A              | = | cross-sectional area  | (m <sup>2</sup> )   |
| P              | = | wetted perimeter  | (m)                 |
| S <sub>f</sub> | = | friction gradient or slope of energy line                   |                     |
| n              | = | Manning's roughness coefficient (see Tables 4.8, 4.9, 4.10) |                     |

**Table 4.8** Effective absolute roughness and friction formula coefficients<sup>3</sup>

| Conduit Material  | Manning n   |
|---|-------------|
| Closed conduits   |             |
| Asbestos-cement pipe  | 0.011-0.015 |
| Brick   | 0.013-0.017 |
| Cast iron pipe  |             |
| Uncoated (new)  | —           |
| Asphalt dipped (new)  | —           |
| Cement-lined & seal coated                                      | 0.011-0.015 |
| Concrete (monolithic)   |             |
| Smooth forms  | 0.012-0.014 |
| Rough forms   | 0.015-0.017 |
| Concrete pipe   | 0.011-0.015 |
| Plastic pipe (smooth)   | 0.011-0.015 |
| Vitrified clay  |             |
| Pipes   | 0.011-0.015 |
| Liner plates  | 0.013-0.017 |
| Open channels   |             |
| Lined channels  |             |
| a. Asphalt  | 0.013-0.017 |
| b. Brick  | 0.012-0.018 |
| c. Concrete   | 0.011-0.020 |
| d. Rubble or riprap   | 0.020-0.035 |
| e. Vegetal  | 0.030-0.40  |
| Excavated or dredged  |             |
| Earth, straight and uniform                                     | 0.020-0.030 |
| Earth, winding, fairly uniform                                  | 0.025-0.040 |
| Rock  | 0.030-0.045 |
| Unmaintained  | 0.050-0.14  |
| Natural Channels (minor streams, top width at flood stage <30m) |             |
| Fairly regular section  | 0.030-0.070 |
| Irregular section with pools                                    | 0.040-0.10  |

**Table 4.9** Values of coefficient of roughness (n) for standard corrugated steel pipe (Manning's formula)\*

| Corrugations | Annular<br>68 x 13 mm<br>All<br>Diametres | Helical              |       |           |        |        |        |        |        |        |  |
|--------------|---|----------------------|-------|-----------|--------|--------|--------|--------|--------|--------|--|
|              |   | 38 x 65 mm           |       | 68 x 13mm |        |        |        |        |        | 1400 & |  |
|              |   | 200                  | 250   | 300       | 400    | 500    | 600    | 900    | 1200   | Larger |  |
| Unpaved      | 0.024                                     | 0.012                | 0.011 | 0.013     | 0.014  | 0.015  | 0.018  | 0.018  | 0.020  | 0.021  |  |
| 25% Paved    | 0.021                                     |                      |       |           |        |        | 0.014  | 0.017  | 0.020  | 0.019  |  |
| Fully Paved  | 0.012                                     |                      |       |           |        |        | 0.012  | 0.012  | 0.012  | 0.012  |  |
| Corrugations | Annular<br>76 x 25 mm                     | Helical - 76 x 25mm  |       |           |        |        |        |        | 2200 & |        |  |
|              |   | 1200                 |       | 1400      |        | 1600   |        | 1800   |        | 2000   |  |
|              |   | 1200                 | 1400  | 1600      | 1800   | 2000   | Larger |        |        |        |  |
| Unpaved      | 0.027                                     | 0.023                | 0.023 | 0.024     | 0.025  | 0.026  | 0.027  |        |        |        |  |
| 25% Paved    | 0.023                                     | 0.020                | 0.020 | 0.021     | 0.022  | 0.022  | 0.023  |        |        |        |  |
| Fully Paved  | 0.012                                     | 0.012                | 0.012 | 0.012     | 0.012  | 0.012  | 0.012  |        |        |        |  |
| Corrugations | Annular<br>125 x 26 mm                    | Helical - 125 x 26mm |       |           |        | 2000 & |        |        |        |        |  |
|              |   | 1400                 |       | 1600      |        | 1800   |        | Larger |        |        |  |
|              |   | 1400                 | 1600  | 1800      | Larger |        |        |        |        |        |  |
| Unpaved      | 0.025                                     | 0.022                | 0.023 | 0.024     | 0.025  |        |        |        |        |        |  |
| 25% Paved    | 0.022                                     | 0.019                | 0.020 | 0.021     | 0.022  |        |        |        |        |        |  |
| Fully Paved  | 0.012                                     | 0.012                | 0.012 | 0.012     | 0.012  |        |        |        |        |        |  |

\*AISI

**Table 4.10** Values of n for structural plate pipe for 152 x 51mm corrugations (Manning's formula)

| Corrugations<br>152 x 51mm | Diameters |        |        |        |
|----------------------------|-----------|--------|--------|--------|
|                            | 1500mm    | 2120mm | 3050mm | 4610mm |
| Plain - unpaved            | 0.033     | 0.032  | 0.030  | 0.028  |
| 25% Paved                  | 0.028     | 0.027  | 0.026  | 0.024  |

Figure 4.8 provides nomographs for estimating steady uniform flows for pipes flowing full, using the Manning equation. In cases where conduits are flowing only partly full, the corresponding hydraulic ratios may be determined from Figures 4.9 and 4.10.

**Kutter Equation**

The Kutter Equation is used for open channel calculations in certain areas of the United States. It is an empirically derived relation between the Chezy coefficient 'C' and the Manning roughness coefficient 'n.'

$$Q = A \cdot C \cdot R^{1/2} \cdot S_f^{1/2}$$

where

$$C = \frac{23 + \frac{0.00155}{S} + \frac{1}{n}}{1 + \frac{n}{\phi R} \left( 23 + \frac{0.00155}{S} \right)}$$



Although the friction slope  $S_f$  appears as a second order term in the expression for 'C' the resulting discharge is not sensitive to this term. Table 4.11 shows the difference (%) in discharge computed using the Kutter equation compared with that obtained by Manning. The table gives the relationship between the diameter (D) and the hydraulic radius (R) assuming full flow in a circular pipe. The values in Table 4.11 are also valid for noncircular pipes flowing partially full.

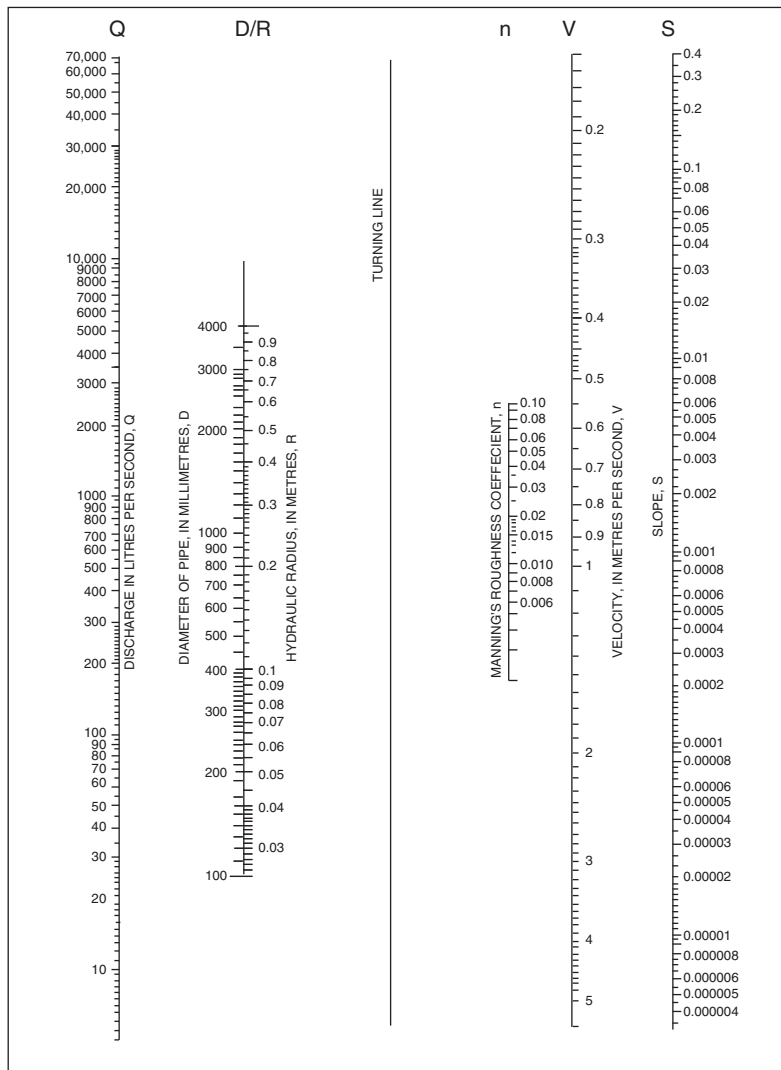

Alignment chart for energy loss in pipes, for Manning's formula.  
 Note: Use chart for flow computations,  $H_L = S$

**Figure 4.8** Nomograph for solution of Manning's formula

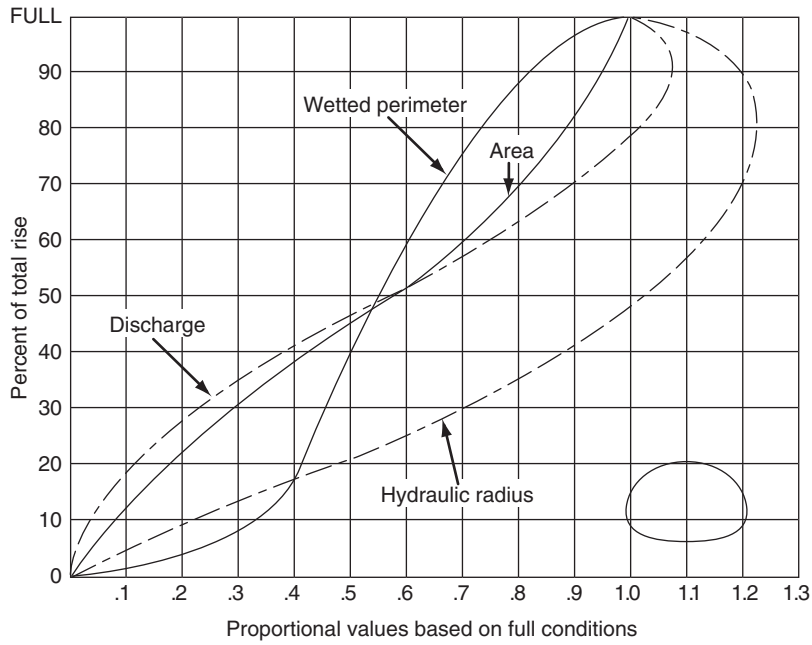

Figure 4.9 Hydraulic properties of corrugated steel and structural plate pipe-arches

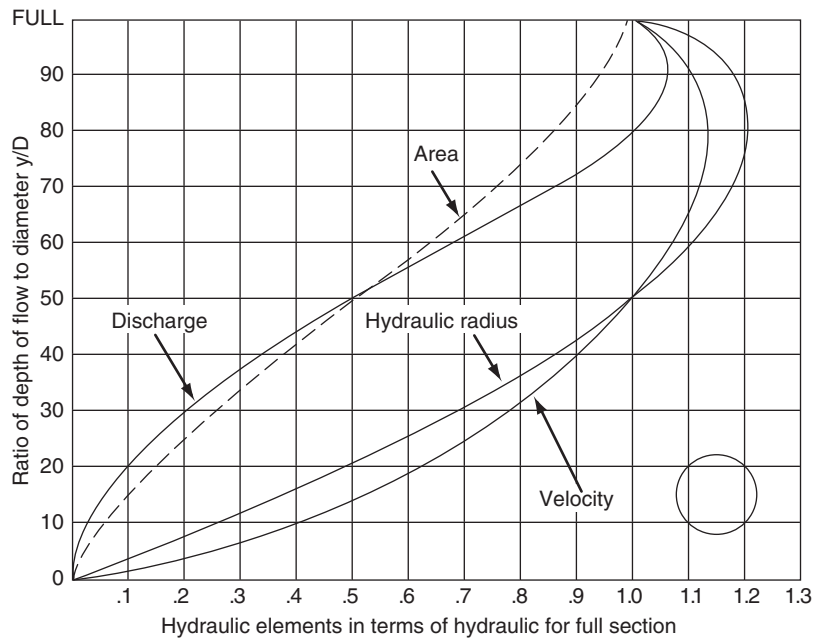

Figure 4.10 Hydraulic elements graph for circular CSP

**Table 4.11** Percent difference of Kutter equation compared with Manning equation (Grade = 1.0%)

| n        |          | 0.013 | 0.02  | 0.03  |
|----------|----------|-------|-------|-------|
| D-metres | R-metres |       |       |       |
| 0.5      | 0.125    | -0.31 | -5.50 | -6.74 |
| 1        | 0.25     | 1.15  | -2.20 | -3.62 |
| 1.5      | 0.375    | 1.34  | -0.96 | -2.19 |
| 2        | 0.5      | 1.20  | -0.38 | -1.35 |
| 2.5      | 0.625    | 0.94  | -0.11 | -0.82 |
| 3        | 0.75     | 0.64  | 0.01  | -0.45 |
| 3.5      | 0.875    | 0.32  | 0.03  | -0.19 |
| 4        | 1        | 0.00  | 0.00  | 0.00  |
| 4.5      | 1.125    | -0.32 | -0.07 | 0.14  |
| 5        | 1.25     | -0.62 | -0.16 | 0.24  |
| 5.5      | 1.375    | -0.92 | -0.27 | 0.31  |
| 6        | 1.5      | -1.21 | -0.39 | 0.36  |

The two equations give identical results for values of R close to 1.0m which represents a very large pipe of perhaps 3600mm diameter. For smaller sized conduits, the difference is significant especially where the roughness coefficient is large.

#### SOLVING THE FRICTION LOSS EQUATION

Of the three quantities ( $Q$ ,  $S_f$ ,  $y_o$ ) of greatest interest in open channel analysis the discharge  $Q$  and the friction slope  $S_f$  are easily obtained as they appear explicitly in the equations. Because of the exponential form of the Manning equation it is a simple matter to compute the friction slope  $S_f$  as a function of velocity or discharge for known cross-sectional properties. Even with the Kutter equation, the second order term in  $S_f$  is of little importance and can be safely ignored as a first iteration when solving for  $S_f$ .

The third quantity is the normal depth  $y_o$ , which is the depth at which uniform flow would take place in a very long reach of channel. The normal depth is less easily determined as it appears in the expressions for both area  $A$  and hydraulic radius  $R$ . A trial and error solution is required except for sections of straightforward geometry.

For partially-full circular channels a convenient semi-graphical method of solution is provided by the curves describing proportional ratios of discharge, hydraulic radius, area and velocity expressed as a function of the relative depth  $y/D$ . Two simple examples should give an indication of how these curves can be used:

Example 1: Finding the normal depth  $y_o$ .

A pipe of diameter 1.0m ( $n = 0.013$ ) has a gradient of 1.0% . It is required to find the normal depth  $y_o$  for a discharge of 2 m<sup>3</sup>/s

Step 1: Calculate the full-pipe capacity using Manning's equation for  $D = 1.0$  m

For full-pipe flow  $R = D/4 = 0.25$  m

$$Q = \frac{\pi}{4} (1)^2 (0.25)^{2/3} (0.01)^{1/2} / 0.013 = 2.4 \text{ m}^3/\text{s}$$

- Step 2: Get the proportional discharge  $Q_{act}/Q_{full} = 2/2.4 = 0.83$   
 Step 3: From the 'Discharge' curve of Figure 4.10 find the corresponding proportional depth  $y/D = 0.68$ . Thus the normal depth is given by:  
 $y_o = 0.68 \times 1 = 0.68\text{m}$

Example 2: Designing for a range of flows.

A pipe is designed to carry a minimum discharge of  $0.12\text{m}^3/\text{s}$ . With a velocity not less than  $1.0\text{m/s}$  and a maximum discharge  $0.6\text{m}^3/\text{s}$  without surcharging. Use the flattest gradient possible. ( $n = 0.013$ )

- Step 1: Assuming  $Q_{full} = Q_{max} = 0.6$ ;  $Q_{min} / Q_{full} = 0.12 / 0.6 = 0.2$   
 Step 2: This corresponds to  $y/D = 0.31$  which in turn corresponds to a proportional velocity of  $V_{min} / V_{full} = 0.78$  (Figure 4.9).  
 Thus the full pipe velocity corresponding to  $V_{min} = 1.0\text{ m/s}$  is given by:  
 $V_{full} = 1.0 / 0.78 = 1.28\text{ m/s}$   
 Step 3: Thus for full pipe flow the required section area is given by:  
 $A = Q_{max} / V_{full} = 0.6 / 1.28 = 0.47\text{m}^2$   
 or  $D = (4 A/\pi)^{1/2} = 0.77\text{m}$   
 Step 4: Assuming that commercial sizes are available in increments of 100mm the selected diameter must be rounded down (to ensure  $V_{min} > 1.0\text{ m/s}$ ) to 700mm  
 Step 5: The necessary slope is then obtained from the Manning equation as  

$$S_o = S_r = \frac{Q^2 n^2}{A^2 R^{4/3}}$$
 where  $A = \pi D^2/4 = 0.38\text{m}^2$  and  $R = D/4 = 0.175\text{m}$   
 Thus the required grade is  $S_o = 0.0043$  or approximately 0.4%

### SURFACE WATER PROFILES

Uniform flow is seldom attained except in very long reaches, free from any form of transition. Gradually varied flow occurs as a form of gentle transition from one stage of uniform flow to another and non-uniform flow is found to be the rule rather than the exception.

The flow profiles of gradually varied flow can be classified in relation to the normal depth  $y_o$  and the critical depth  $y_{cr}$  and the slope of the channel.

Channel slope is described as:

- (1) MILD when  $y_o > y_{cr}$  i.e.  $S_o < S_{cr}$ .  
 (2) STEEP when  $y_o < y_{cr}$  i.e.  $S_o > S_{cr}$ .

Note that the critical slope  $S_{cr}$  is slightly dependent on the stage or magnitude of flow, so that strictly speaking the description of Mild or Steep should not be applied to the channel without regard to the flow conditions.

Most textbooks show five classes of channel slope: Mild, Steep, Critical, Horizontal and Adverse. In practice the last three categories are special cases of the first two and it is sufficient to consider them. In addition to the channel slope, a profile of gradually varied flow can be classified depending on whether it lies above, below or between the normal and critical depths. The three zones may be defined as follows.

- Zone I — Profile lies above both  $y_o$  and  $y_{cr}$   
 Zone 2 — Profile lies between  $y_o$  and  $y_{cr}$   
 Zone 3 — Profile lies below both  $y_o$  and  $y_{cr}$

Using the capitals 'M' and 'S' to denote Mild or Steep channel state and the Zone number '1', '2' or '3,' profiles may be classified as 'M<sub>1</sub>' or 'S<sub>3</sub>.' Figure 4.11 shows the idealized cases of the six basic profile types along with typical circumstances in which they can occur.

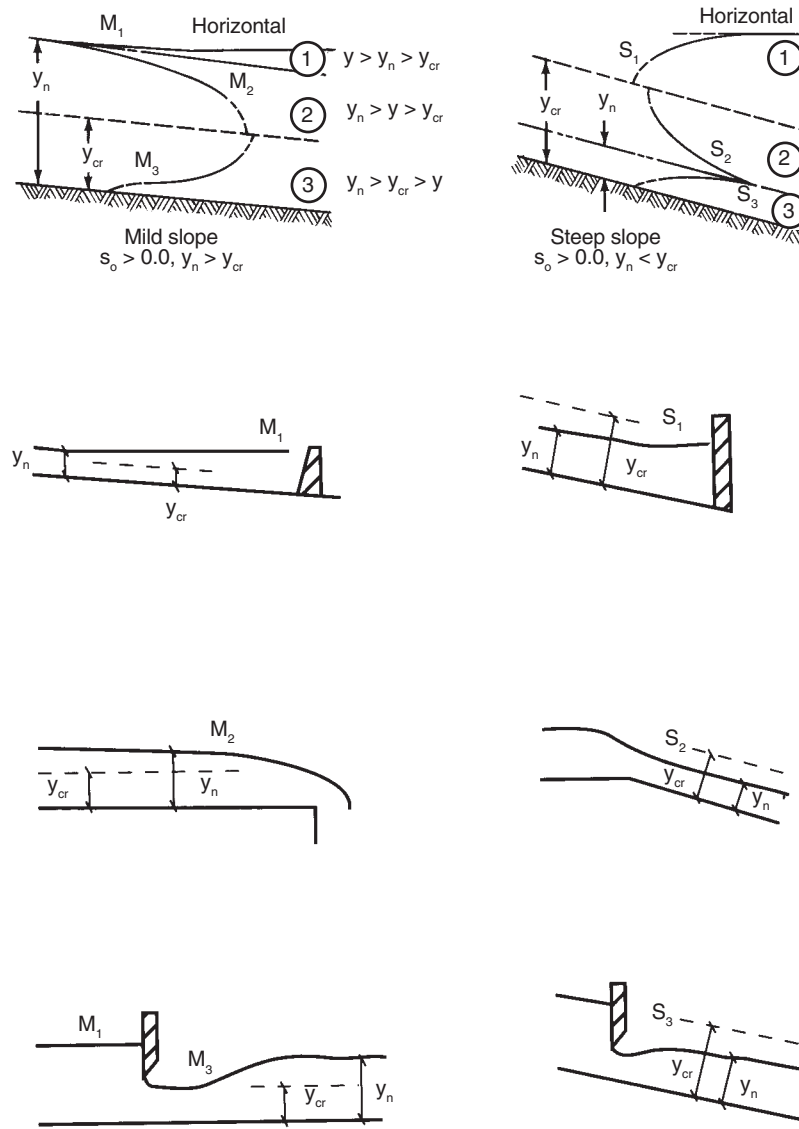

Figure 4.11 Idealized flow profile

### HYDRAULIC JUMP

When supercritical flow enters a reach in which the flow is subcritical, an abrupt transition is formed which takes the form of a surface roller or undular wave which tries to move upstream but which is held in check by the velocity of the supercritical flow. Figure 4.12 shows a typical situation in which supercritical uniform flow from a steep reach enters a reach of mild slope in which the normal depth is subcritical.

The energy losses associated with the violent turbulence of the hydraulic jump make application of the Bernoulli equation impossible. Instead, the control volume of fluid containing the jump can be analyzed using the equation of conservation of momentum. For a prismatic channel of arbitrary cross-section this can be expressed as follows:

$$Q^2/(g A_1) + A_1 \bar{y}_1 = Q^2/(g A_2) + A_2 \bar{y}_2$$

where  $\bar{y}$  = depth to the centroid of the cross-section

$A$  = cross-sectional area

$Q$  = total discharge

$g$  = gravitational acceleration

For the special case of a rectangular cross-section, the solution can be obtained directly using the discharge per unit breadth:

$$y_2 = -(y_1/2) + (y_1^2/4 + 2q^2/(gy_1))^{1/2}$$

where  $y_2$  = depth downstream of the jump

$y_1$  = depth upstream of the jump

$q$  = discharge per unit breadth of channel

$g$  = gravitational acceleration

The above equation is reversible so that  $y_1$  may be found as a function of  $y_2$  using a similar relationship.

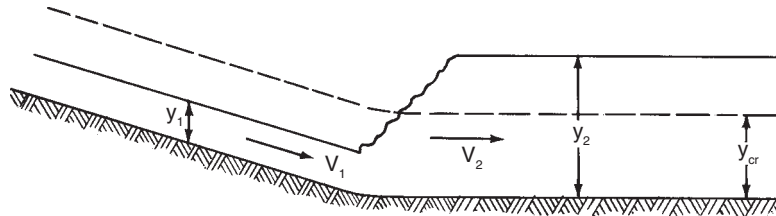

Figure 4.12 Hydraulic jump

### FORM LOSSES IN JUNCTIONS, BENDS AND OTHER STRUCTURES

From the time storm water first enters the sewer system at the inlet until it discharges at the outlet, it will encounter a variety of hydraulic structures such as manholes, bends, contractions, enlargements and transitions, which will cause velocity head losses. These losses have been called "minor losses". This is misleading. In some situations these losses are as important as those arising from pipe friction. Velocity losses may be expressed in a general form derived from the Bernoulli and Darcy-Weisbach equations.

$$H = K \frac{V^2}{2g}$$

where:  $H$  = velocity head loss

$K$  = coefficient for the particular structure

The following are useful velocity head loss formulae of hydraulic structures commonly found in sewer systems. They are primarily based on experiments.

#### Transition Losses (open channel)

The energy losses may be expressed in terms of the kinetic energy at the two ends:

$$H_t = K_t \left[ \frac{V^2}{2g} \right] \text{ where } K_t \text{ is the transition loss coefficient}$$

Contraction:

$$H_t = 0.1 \left( \frac{V_2^2}{2g} - \frac{V_1^2}{2g} \right) \text{ when } V_2 > V_1$$

Expansion:

$$H_t = 0.2 \left( \frac{V_1^2}{2g} - \frac{V_2^2}{2g} \right) \text{ when } V_1 > V_2$$

Where  $V_1$  = upstream velocity

$V_2$  = downstream velocity

Simple transition in size in a manhole with straight-through flow may be analyzed with the above equations.

#### Transition Losses (pressure flow)

Contraction:

$$H_t = K \left( \frac{V_2^2}{2g} \right) \left[ 1 - \left( \frac{A_2}{A_1} \right) \right]^2$$

$K = 0.5$  for sudden contraction

$K = 0.1$  for well designed transition

and  $A_1, A_2$  = cross-sectional area of flow of incoming and outgoing pipe from transition.

Expansion:

$$H_t = K \left[ \frac{(V_1 - V_2)^2}{2g} \right]$$

$K = 1.0$  for sudden expansion

$K = 0.2$  for well designed transition

The above  $K$  values are for estimating purposes. If a more detailed analysis of the transition losses is required, then the tables in conjunction with the energy losses equation in the form below should be used for pressure flow.

$$H_t = K \left( \frac{V^2}{2g} \right)$$



**Table 4.12** Values of  $K_2$  for determining loss of head due to sudden enlargement in pipes, from the formula  $H_2 = K_2(V_1^2/2g)$

$d_2/d_1$  = ratio of larger pipe to smaller pipe  $V_1$  = velocity in smaller pipe

| $d_2/d_1$ | Velocity, $V_1$ , in metres per second |      |     |     |     |     |     |     |     |     |     |     |      |
|-----------|--|------|-----|-----|-----|-----|-----|-----|-----|-----|-----|-----|------|
|           | 0.6                                    | 0.9  | 1.2 | 1.5 | 1.8 | 2.1 | 2.4 | 3.0 | 3.6 | 4.5 | 6.0 | 9.0 | 12.0 |
| 1.2       | .11                                    | .10  | .10 | .10 | .10 | .10 | .10 | .09 | .09 | .09 | .09 | .09 | .08  |
| 1.4       | .26                                    | .26  | .25 | .24 | .24 | .24 | .24 | .23 | .23 | .22 | .22 | .21 | .20  |
| 1.6       | .40                                    | .39  | .38 | .37 | .37 | .36 | .36 | .35 | .35 | .34 | .33 | .32 | .32  |
| 1.8       | .51                                    | .49  | .48 | .47 | .47 | .46 | .46 | .45 | .44 | .43 | .42 | .41 | .40  |
| 2.0       | .60                                    | .58  | .56 | .55 | .55 | .54 | .53 | .52 | .52 | .51 | .50 | .48 | .47  |
| 2.5       | .74                                    | .72  | .70 | .69 | .68 | .67 | .66 | .65 | .64 | .63 | .62 | .60 | .58  |
| 3.0       | .83                                    | .80  | .78 | .77 | .76 | .75 | .74 | .73 | .72 | .70 | .69 | .67 | .65  |
| 4.0       | .92                                    | .89  | .87 | .85 | .84 | .83 | .82 | .80 | .79 | .78 | .76 | .74 | .72  |
| 5.0       | .96                                    | .93  | .91 | .89 | .88 | .87 | .86 | .84 | .83 | .82 | .80 | .77 | .75  |
| 10.0      | 1.00                                   | .99  | .96 | .95 | .93 | .92 | .91 | .89 | .88 | .86 | .84 | .82 | .80  |
| $\infty$  | 1.00                                   | 1.00 | .98 | .96 | .95 | .94 | .93 | .91 | .90 | .88 | .86 | .83 | .81  |

**Table 4.13** Values of  $K_2$  for determining loss of head due to gradual enlargement in pipes, from the formula  $H_2 = K_2(V_1^2/2g)$

$d_2/d_1$  = ratio of diameter of larger pipe to diameter of smaller pipe. Angle of cone is twice the angle between the axis of the cone and its side.

| $d_2/d_1$ | Angle of cone |            |            |            |             |             |             |             |             |             |             |             |             |             |
|-----------|---------------|------------|------------|------------|-------------|-------------|-------------|-------------|-------------|-------------|-------------|-------------|-------------|-------------|
|           | 2 $\gamma$    | 4 $\gamma$ | 6 $\gamma$ | 8 $\gamma$ | 10 $\gamma$ | 15 $\gamma$ | 20 $\gamma$ | 25 $\gamma$ | 30 $\gamma$ | 35 $\gamma$ | 40 $\gamma$ | 45 $\gamma$ | 50 $\gamma$ | 60 $\gamma$ |
| 1.1       | .01           | .01        | .01        | .02        | .03         | .05         | .10         | .13         | .16         | .18         | .19         | .20         | .21         | .23         |
| 1.2       | .02           | .02        | .02        | .03        | .04         | .09         | .16         | .21         | .25         | .29         | .31         | .33         | .35         | .37         |
| 1.4       | .02           | .03        | .03        | .04        | .06         | .12         | .23         | .30         | .36         | .41         | .44         | .47         | .50         | .53         |
| 1.6       | .03           | .03        | .04        | .05        | .07         | .14         | .26         | .35         | .42         | .47         | .51         | .54         | .57         | .61         |
| 1.8       | .03           | .04        | .04        | .05        | .07         | .15         | .28         | .37         | .44         | .50         | .54         | .58         | .61         | .65         |
| 2.0       | .03           | .04        | .04        | .05        | .07         | .16         | .29         | .38         | .46         | .52         | .56         | .60         | .63         | .68         |
| 2.5       | .03           | .04        | .04        | .05        | .08         | .16         | .30         | .39         | .48         | .54         | .58         | .62         | .65         | .70         |
| 3.0       | .03           | .04        | .04        | .05        | .08         | .16         | .31         | .40         | .48         | .55         | .59         | .63         | .66         | .71         |
| $\infty$  | .03           | .04        | .05        | .06        | .08         | .16         | .31         | .40         | .49         | .56         | .60         | .64         | .67         | .72         |

**Table 4.14** Values of  $K_3$  for determining loss of head due to sudden contraction from the formula  $H_3 = K_3(V_2^2/2g)$  $d_2/d_1$  = ratio of larger to smaller diameter       $V_2$  = velocity in smaller pipe

| $\frac{d_2}{d_1}$ | Velocity, $V_2$ , in metres per second |     |     |     |     |     |     |     |     |     |     |     |      |
|-------------------|--|-----|-----|-----|-----|-----|-----|-----|-----|-----|-----|-----|------|
|                   | 0.6                                    | 0.9 | 1.2 | 1.5 | 1.8 | 2.1 | 2.4 | 3.0 | 3.6 | 4.5 | 6.0 | 9.0 | 12.0 |
| 1.1               | .03                                    | .04 | .04 | .04 | .04 | .04 | .04 | .04 | .04 | .04 | .05 | .05 | .06  |
| 1.2               | .07                                    | .07 | .07 | .07 | .07 | .07 | .07 | .08 | .08 | .08 | .09 | .10 | .11  |
| 1.4               | .17                                    | .17 | .17 | .17 | .17 | .17 | .17 | .18 | .18 | .18 | .18 | .19 | .20  |
| 1.6               | .26                                    | .26 | .26 | .26 | .26 | .26 | .26 | .26 | .26 | .25 | .25 | .25 | .24  |
| 1.8               | .34                                    | .34 | .34 | .34 | .34 | .34 | .33 | .33 | .32 | .32 | .31 | .29 | .27  |
| 2.0               | .38                                    | .38 | .37 | .37 | .37 | .37 | .36 | .36 | .35 | .34 | .33 | .31 | .29  |
| 2.2               | .40                                    | .40 | .40 | .39 | .39 | .39 | .39 | .38 | .37 | .37 | .35 | .33 | .30  |
| 2.5               | .42                                    | .42 | .42 | .41 | .41 | .41 | .40 | .40 | .39 | .38 | .37 | .34 | .31  |
| 3.0               | .44                                    | .44 | .44 | .43 | .43 | .43 | .42 | .42 | .41 | .40 | .39 | .36 | .33  |
| 4.0               | .47                                    | .46 | .46 | .46 | .45 | .45 | .45 | .44 | .43 | .42 | .41 | .37 | .34  |
| 5.0               | .48                                    | .48 | .47 | .47 | .47 | .46 | .46 | .45 | .45 | .44 | .42 | .38 | .35  |
| 10.0              | .49                                    | .48 | .48 | .48 | .48 | .47 | .47 | .46 | .46 | .45 | .43 | .40 | .36  |
| $\infty$          | .49                                    | .49 | .48 | .48 | .48 | .47 | .47 | .47 | .46 | .45 | .44 | .41 | .38  |

**Entrance Losses**

$$H_e = K_e \frac{V^2}{2g}$$

**Table 4.15** Entrance loss coefficients for corrugated steel pipe or pipe-arch

| Inlet End of Culvert                             | Coefficient $K_e$ |
|--|-------------------|
| Projecting from fill (no headwall)               | 0.9               |
| Headwall, or headwall and wingwalls square-edged | 0.5               |
| Mitered (beveled) to conform to fill slope       | 0.7               |
| *End-Section conforming to fill slope            | 0.5               |
| Headwall, rounded edge                           | 0.2               |
| Beveled Ring                                     | 0.25              |

\*End Sections available from manufacturers.

**Manhole Losses**

Manhole losses in many cases comprise a significant percentage of the overall losses within a sewer system. Consequently, if these losses are ignored, or underestimated, the sewer system may surcharge leading to basement flooding or sewer overflows. Losses at sewer junctions are dependent upon flow characteristics, junction geometry and relative sewer diameters. General problems with respect to flow through junctions have been discussed by Chow<sup>8</sup> who concluded that the losses could be best estimated by experimental analysis as opposed to analytical procedures.

Marsalek<sup>9</sup>, in a study for three junction designs found the following:

- i) In pressurized flow the most important flow variable was the relative lateral inflow for junctions with more than two pipes. The losses increased as the ratio of the lateral discharge to main line discharge increased.
- ii) Among the junction geometrical parameters, the important ones are: relative pipe sizes, junction benching and pipe alignment. Base shape and relative manhole sizes were less influential.
- iii) Full benching to the crown of the pipe significantly reduced losses as compared to benching to the mid-section of the pipe or no benching.
- iv) In junctions where two lateral inflows occurred, the head losses increased as the difference in flows between the two lateral sewers increased. The head loss was minimized when the lateral flows were equal.

Various experimental studies<sup>10, 11, 12, 13, 14, 15</sup> have been performed to estimate manhole losses. These works should be referred to whenever possible. In cases where no applicable results are available, the following may be used as a guideline to estimate manhole losses.

#### Manhole Losses (flow straight through)

In a straight through manhole where there is no change in pipe size, losses can be estimated by:

$$H_m = 0.05 \frac{V^2}{2g}$$

#### Terminal Manhole Losses

Losses at terminal manholes may be estimated by the formula:

$$H_{tm} = \frac{V^2}{2g}$$

#### Manhole Junction Losses

Losses at junctions where one or more incoming laterals occur may be estimated by combining the laws of pressure plus momentum where  $H_j$  is equal to the junction losses.

$$H_j = K_j \frac{V^2}{2g}$$

Using the laws of pressure plus momentum:

$$(H_j + D_1 - D_2) \frac{(A_1 + A_2)}{2} = \frac{Q_2^2}{A_2g} - \frac{Q_1^2}{A_1g} - \frac{Q_3^2}{A_3g} \cos \theta$$

The diagram illustrates a manhole junction. A horizontal pipe labeled '1' flows from left to right, indicated by an arrow labeled 'Flow'. This pipe enters a manhole labeled '2'. A second pipe, labeled '3', enters the manhole from the top at an angle  $\theta$  relative to the horizontal. The diagram shows the flow directions and the geometry of the junction.

**Bend Losses**

Bend losses may be estimated from the equation:

$$H_b = K_b \frac{V^2}{2g}$$

For curved sewer segments where the angle is less than 40° the bend loss coefficient may be estimated as:

$$K_b = 0.25 \sqrt{\frac{\Theta}{90}}$$

where:  $\Theta$  = central angle of bend in degrees

For greater angles of deflection and bends in manholes the bend loss coefficient may be determined from Figure 4.13.

**HYDRAULICS OF STORM INLETS****Hydraulics of Storm Water Inlets**

Storm water inlets are the means by which storm runoff enters the sewer system. Their design is often neglected or receives very little attention during the design of storm drainage systems. Inlets play an important role in road drainage and storm sewer design because of their effect on both the rate of water removal from the road surface and the degree of utilization of the sewer system. If inlets are unable to discharge the design inflow to the sewer system it may result in a lower level of roadway convenience and conditions hazardous to traffic. It may also lead to overdesign of the sewer pipes downstream of the inlet. In some cases the limited capacity of the inlets may be desirable as a storm water management alternative thereby offering a greater level of protection from excessive sewer surcharging. In such cases, both the quantity of runoff intercepted and the resulting level of roadway convenience must be known. Furthermore, overdesign in the number of inlets results in higher costs and could result in over-utilization of the sewer system.

No one inlet type is best suited for all conditions. Many different types of inlets have thus been developed, as shown in Figure 4.17. In the past, the hydraulic capacities of some of these inlets was often unknown, sometimes resulting in erroneous capacity estimates.

Storm water inlets may not intercept all runoff due to the velocity of flow over the inlet and the spread of flow across the roadway and gutter. This leads to the concept of carryover flow. As carryover flow progresses downstream, it may accumulate, resulting in a greater demand for interception. It is imperative that more emphasis be placed on inlet design to assure that the inlet type, location and capacity are adequately determined to achieve the overall drainage requirements.

The hydraulic efficiency of inlets is a function of street grade, cross-slope, inlet geometry and curb and gutter design. Generally, an increased street cross-slope will result in increased inlet capacity as the flow is concentrated within the gutter. The depth of flow in the gutter may be estimated from Figure 4.14. The effect of street grades on inlet capacities

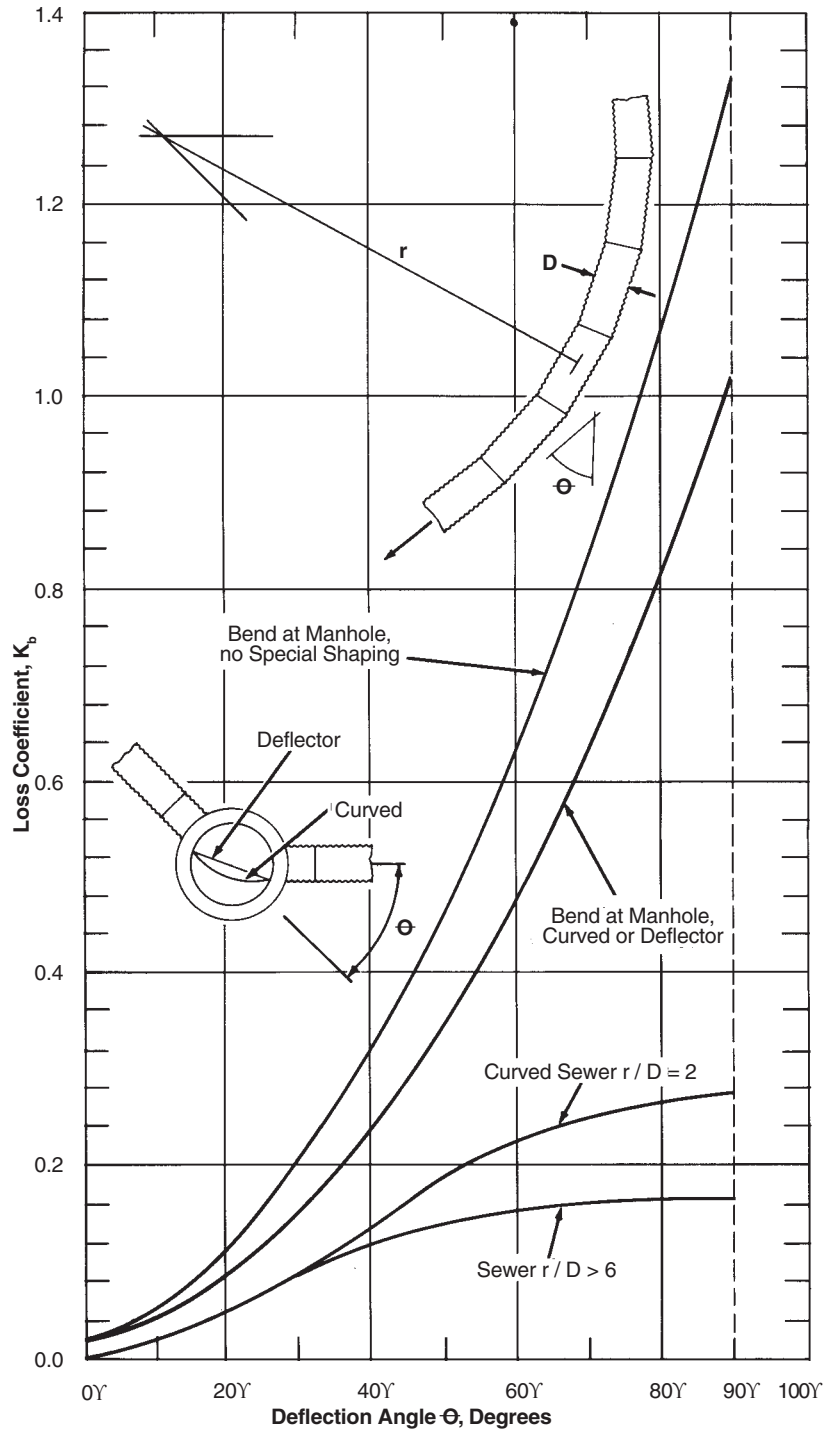

Figure 4.13 Sewer bend loss coefficient<sup>16</sup>

varies. Initially as the street grade increases there is an increase in gutter flow velocity which allows a greater flow to reach the inlets for interception. However, as street grades continue to increase there is a threshold where the velocity is so high that less flow can be intercepted. This threshold velocity depends upon the geometry of the inlet and characteristics of the gutter, see Figures 4.15 and 4.16.

Experiments on inlet capacities<sup>17</sup> have resulted in a set of tables and charts to aid the designer in storm water inlet selection and sewer system design. A sample of the results is shown in Figures 4.15 and 4.16, Tables 4.16 and 4.17.

To use these charts or tables the designer determines the overland flow and the resulting spread in gutter flow from a pre-determined road grade and crossfall, gutter design and inlet type; see Table 4.16. This value is then used with Table 4.17 to obtain the storm water inlet or grate inlet capacity. The difference between the flow on the roadway and the inlet capacity is referred to as the carryover. An illustrative example is presented below:

|                  |   |   |
|------------------|---|---|
| Design Parameter | — | Road crossfall = 0.02 m/m                     |
|                  | — | Road grade = 0.02 m/m                         |
|                  | — | Gutter type B                                 |
|                  | — | Inlet grate type = OPSD-400 (Figure 4.16)     |
|                  | — | One inlet on each side of the road            |
|                  | — | Upstream carryover flow = 0 m <sup>3</sup> /s |
| Catchment Runoff | = | 0.18 m <sup>3</sup> /s                        |
| Gutter Flow      | = | $\frac{0.18}{2} = 0.09$ m <sup>3</sup> /s     |



*Compacting backfill is required for proper installation of all sewers.*

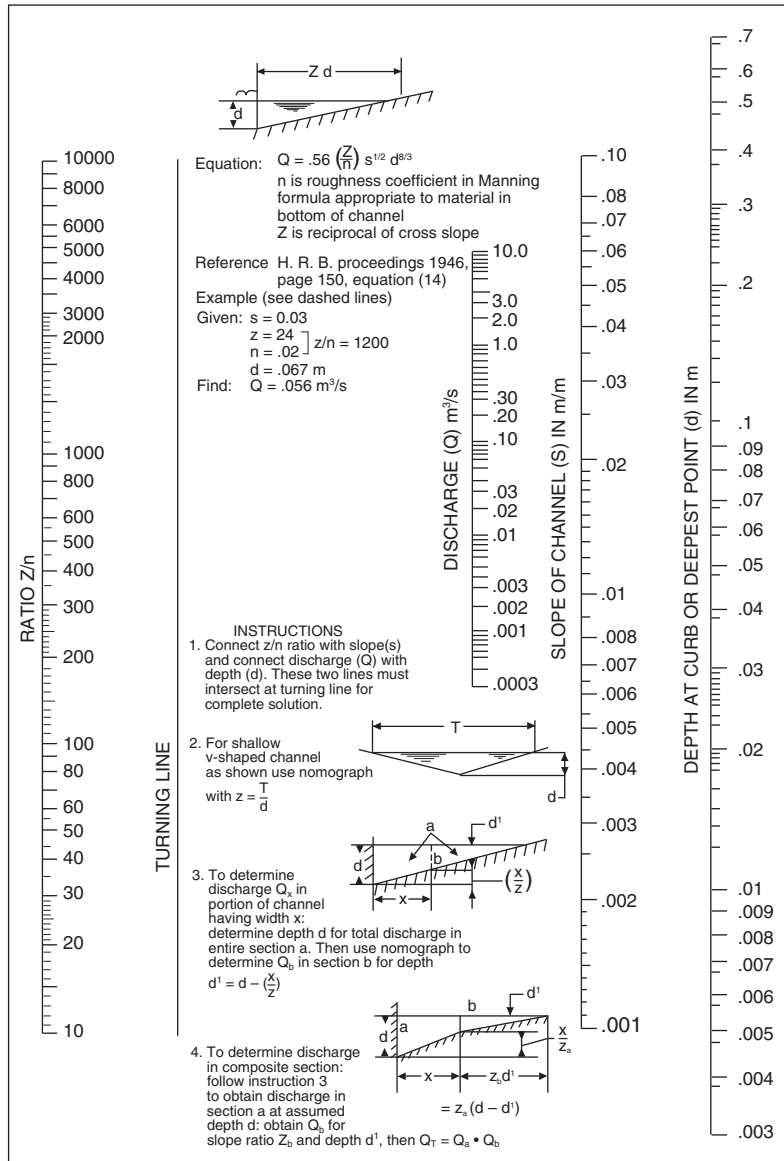

Figure 4.14 Nomograph for flow in triangular channels



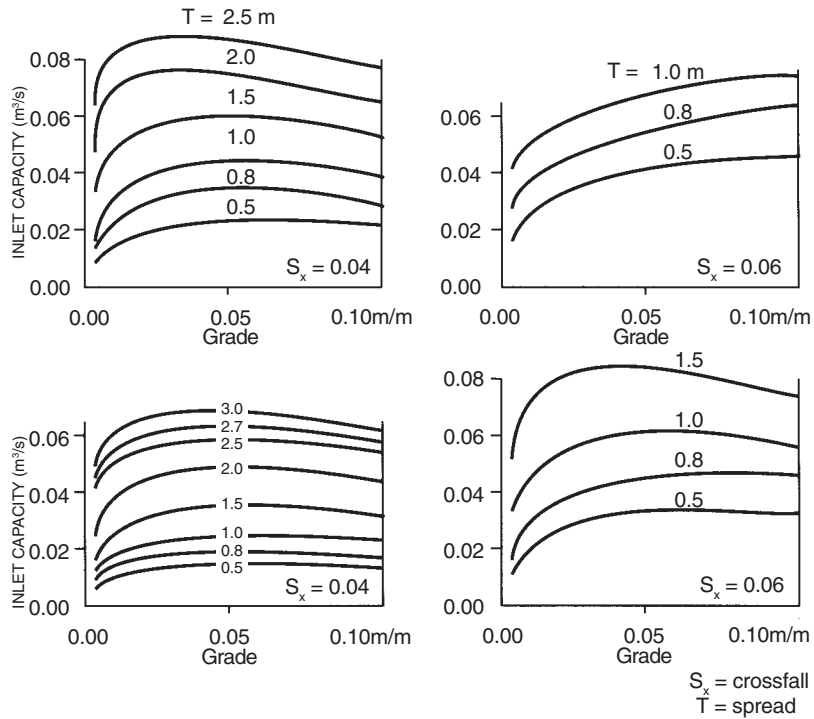

Figure 4.15 Sewer inlet capacity: as per curb and gutter in Figure 4.16

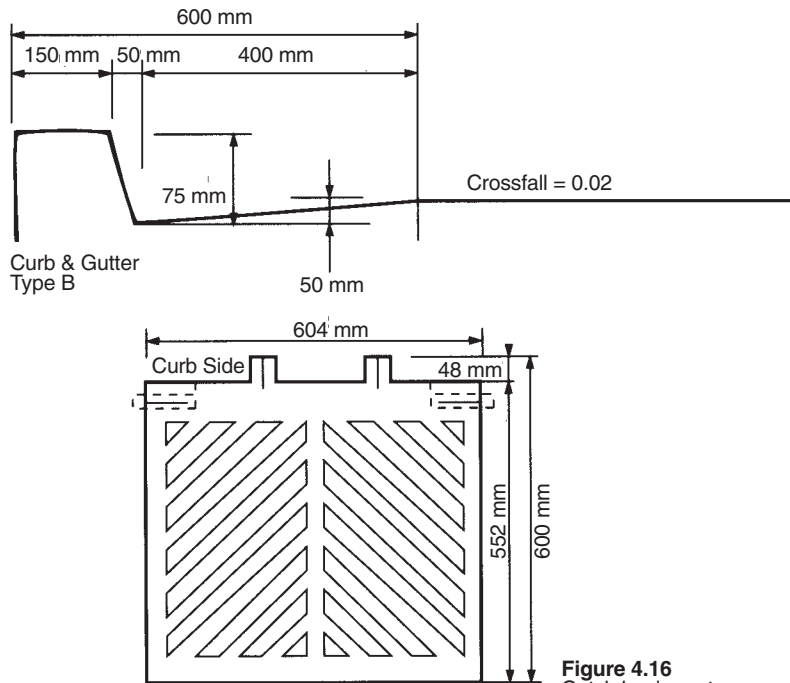

Figure 4.16 Catch basin grate

**Table 4.16** Gutter flow rate<sup>17</sup> (m<sup>3</sup>/s)

| Crossfall<br>(m/m) | Spread<br>(m) | Depth<br>(m) | Grade (m/m) |       |       |       |       |       |       |       |
|--------------------|---------------|--------------|-------------|-------|-------|-------|-------|-------|-------|-------|
|                    |               |              | 0.003       | 0.01  | 0.02  | 0.03  | 0.04  | 0.06  | 0.08  | 0.1   |
| 0.02               | 0.00          | 0.05         | 0.005       | 0.008 | 0.012 | 0.014 | 0.016 | 0.020 | 0.023 | 0.026 |
|                    | 0.50          | 0.06         | 0.008       | 0.014 | 0.020 | 0.024 | 0.028 | 0.034 | 0.039 | 0.044 |
|                    | 0.75          | 0.06         | 0.010       | 0.018 | 0.025 | 0.031 | 0.036 | 0.044 | 0.051 | 0.057 |
|                    | 1.00          | 0.07         | 0.013       | 0.024 | 0.033 | 0.041 | 0.047 | 0.058 | 0.067 | 0.074 |
|                    | 1.50          | 0.08         | 0.022       | 0.039 | 0.055 | 0.068 | 0.078 | 0.096 | 0.110 | 0.123 |
|                    | 2.00          | 0.09         | 0.034       | 0.062 | 0.087 | 0.107 | 0.123 | 0.151 | 0.175 | 0.195 |
|                    | 2.50          | 0.10         | 0.051       | 0.093 | 0.131 | 0.161 | 0.186 | 0.227 | 0.263 | 0.294 |
|                    | 3.00          | 0.11         | 0.059       | 0.108 | 0.153 | 0.187 | 0.216 | 0.264 | 0.305 | 0.341 |
| 0.04               | 0.50          | 0.07         | 0.012       | 0.022 | 0.030 | 0.037 | 0.043 | 0.053 | 0.061 | 0.068 |
|                    | 0.75          | 0.08         | 0.018       | 0.033 | 0.046 | 0.057 | 0.066 | 0.080 | 0.093 | 0.104 |
|                    | 1.00          | 0.09         | 0.026       | 0.048 | 0.068 | 0.084 | 0.097 | 0.118 | 0.136 | 0.153 |
|                    | 1.50          | 0.11         | 0.051       | 0.094 | 0.133 | 0.162 | 0.188 | 0.230 | 0.265 | 0.296 |
|                    | 2.00          | 0.13         | 0.089       | 0.163 | 0.230 | 0.281 | 0.325 | 0.398 | 0.460 | 0.514 |
|                    | 2.50          | 0.15         | 0.142       | 0.258 | 0.365 | 0.447 | 0.517 | 0.633 | 0.731 | 0.817 |
| 0.06               | 0.50          | 0.08         | 0.017       | 0.031 | 0.043 | 0.053 | 0.061 | 0.075 | 0.087 | 0.097 |
|                    | 0.75          | 0.09         | 0.028       | 0.052 | 0.073 | 0.089 | 0.103 | 0.126 | 0.146 | 0.163 |
|                    | 1.00          | 0.11         | 0.044       | 0.080 | 0.114 | 0.140 | 0.161 | 0.197 | 0.228 | 0.255 |
|                    | 1.50          | 0.14         | 0.092       | 0.168 | 0.237 | 0.290 | 0.335 | 0.411 | 0.474 | 0.530 |
|                    | 1.67          | 0.15         | 0.113       | 0.206 | 0.292 | 0.358 | 0.413 | 0.506 | 0.584 | 0.653 |
| 0.08               | 0.50          | 0.09         | 0.023       | 0.042 | 0.059 | 0.072 | 0.083 | 0.102 | 0.117 | 0.131 |
|                    | 0.75          | 0.11         | 0.040       | 0.074 | 0.104 | 0.128 | 0.148 | 0.181 | 0.209 | 0.234 |
|                    | 1.00          | 0.13         | 0.065       | 0.120 | 0.169 | 0.207 | 0.239 | 0.293 | 0.338 | 0.378 |
|                    | 1.25          | 0.15         | 0.099       | 0.181 | 0.255 | 0.313 | 0.361 | 0.442 | 0.511 | 0.571 |

**Table 4.17** Grate inlet capacity<sup>17</sup> (m<sup>3</sup>/s)\*

| Crossfall<br>(m/m) | Spread<br>(m) | Grade (m/m) |       |       |       |       |       |       |       |
|--------------------|---------------|-------------|-------|-------|-------|-------|-------|-------|-------|
|                    |               | 0.00        | 0.01  | 0.02  | 0.03  | 0.04  | 0.06  | 0.08  | 0.10  |
| 0.02               | 0.50          | 0.005       | 0.007 | 0.010 | 0.011 | 0.012 | 0.012 | 0.013 | 0.012 |
|                    | 0.75          | 0.008       | 0.012 | 0.014 | 0.017 | 0.018 | 0.019 | 0.019 | 0.017 |
|                    | 1.00          | 0.010       | 0.014 | 0.018 | 0.021 | 0.022 | 0.023 | 0.024 | 0.022 |
|                    | 1.50          | 0.013       | 0.023 | 0.029 | 0.031 | 0.033 | 0.035 | 0.034 | 0.032 |
|                    | 2.00          | 0.023       | 0.035 | 0.040 | 0.043 | 0.044 | 0.044 | 0.043 | 0.041 |
|                    | 2.50          | 0.034       | 0.046 | 0.052 | 0.054 | 0.054 | 0.054 | 0.052 | 0.050 |
|                    | 2.70          | 0.037       | 0.050 | 0.056 | 0.057 | 0.058 | 0.057 | 0.056 | 0.052 |
|                    | 3.00          | 0.042       | 0.055 | 0.061 | 0.062 | 0.062 | 0.061 | 0.059 | 0.057 |
| 0.04               | 0.50          | 0.007       | 0.013 | 0.017 | 0.020 | 0.022 | 0.024 | 0.024 | 0.021 |
|                    | 0.75          | 0.012       | 0.021 | 0.027 | 0.030 | 0.031 | 0.032 | 0.031 | 0.028 |
|                    | 1.00          | 0.016       | 0.027 | 0.035 | 0.039 | 0.040 | 0.042 | 0.040 | 0.038 |
|                    | 1.50          | 0.027       | 0.046 | 0.054 | 0.057 | 0.058 | 0.056 | 0.053 | 0.050 |
|                    | 2.00          | 0.042       | 0.064 | 0.070 | 0.071 | 0.071 | 0.070 | 0.068 | 0.064 |
|                    | 2.50          | 0.057       | 0.078 | 0.081 | 0.081 | 0.080 | 0.076 | 0.073 | 0.072 |
| 0.06               | 0.50          | 0.010       | 0.015 | 0.021 | 0.024 | 0.026 | 0.028 | 0.030 | 0.030 |
|                    | 0.75          | 0.019       | 0.028 | 0.033 | 0.036 | 0.039 | 0.042 | 0.044 | 0.043 |
|                    | 1.00          | 0.030       | 0.042 | 0.048 | 0.052 | 0.054 | 0.056 | 0.055 | 0.051 |
|                    | 1.50          | 0.048       | 0.062 | 0.069 | 0.071 | 0.072 | 0.071 | 0.068 | 0.063 |
| 0.08               | 0.50          | 0.013       | 0.023 | 0.029 | 0.032 | 0.035 | 0.038 | 0.038 | 0.038 |
|                    | 0.75          | 0.027       | 0.038 | 0.042 | 0.046 | 0.049 | 0.054 | 0.057 | 0.057 |
|                    | 1.00          | 0.038       | 0.050 | 0.047 | 0.061 | 0.063 | 0.068 | 0.072 | 0.074 |

\*Grate shown in Figure 4.16.

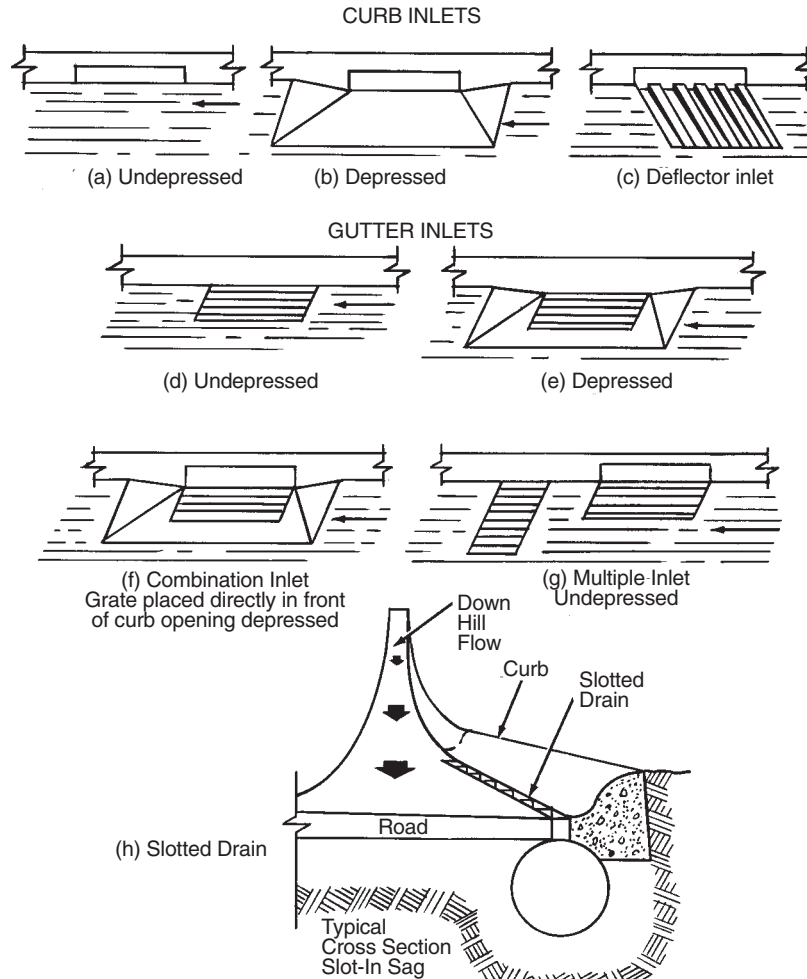

**Figure 4.17** Stormwater inlets

From Table 4.16 the resulting spread in flow = 2.00m. From Table 4.17, 2.00m of spread results in an inlet capacity of 0.040 m<sup>3</sup>/s. Therefore, the total flow intercepted = 2x0.040 = 0.080 m<sup>3</sup>/s. The carryover flow = 0.18 - 0.08 = 0.10 m<sup>3</sup>/s.

For roads where few restrictions to inlet location may exist (i.e., highways and arterial roads), these charts can be used to establish minimum spacing between inlets. This is done by controlling the catchment area for each inlet. The area is simplified to a rectangular shape of width and length where the length represents the distance between inlets.

Under special circumstances it may be necessary to install twin or double inlets to increase the inlet capacity. For reasons of interference by traffic such installations are usually installed in series, parallel to the curb. Studies<sup>17</sup> have shown that where such installations exist on a continuous grade, the increases in inlet capacity rarely exceed 50 percent of the single inlet capacity.

The capacity of storm water inlets at a sag in the roadway is typically expressed by weir and orifice equations.<sup>17</sup> Flow into the inlets initially operates as a weir having a crest length equal to the length of perimeter which flow crosses. The inlet operates under these conditions to a depth of about 100mm. The quantity intercepted is expressed by the following:

$$Q = 0.154 LD^{1.5}$$

Where  $Q$  = rate of discharge into the grate opening ( $m^3/s$ )

$L$  = perimeter length of the grate, disregarding bars and neglecting the side against the curb (m)

$D$  = depth of water at the grate (m)

When the depth exceeds 0.12m the inlet begins to operate as an orifice and its discharge is expressed by the following:

$$Q = 0.154 AD^{0.5}$$

Where  $Q$  = rate of discharge into the grate opening ( $m^3/s$ )

$A$  = clear opening of the grate ( $m^2$ )

$D$  = depth of water ponding above the top of the grate (m)

The inlet capacity of an undepressed curb inlet may be expressed by the equation:

$$Q/l = 1.47 \times 10^{-3} d \sqrt{g/d}$$

where  $Q$  = discharge into inlets ( $m^3/s$ )

$l$  = length of opening (m)

$g$  = gravitational acceleration ( $m^3/s$ )

$d$  = depth of flow in gutter (m)

or

$$Q/l = 0.25 i^{0.579} \left( \frac{Q_o}{\sqrt{s/n}} \right)^{0.563}$$

This assumes a gutter of wedge shaped cross-section with a cross-sectional street slope of  $10^{-3}$  to  $10^{-1}$  with

$Q_o$  = flow in the gutter ( $m^3/s$ )

$i$  = transverse slope

$s$  = hydraulic gradient of gutter

$n$  = coefficient of roughness of gutter

The inlet capacity for a slotted drain may be determined from Figure 4.19. The advantages of carryover are shown in Figure 4.18. If carryover is to be permitted, assume a length ( $L_A$ ) such that  $L_A/L_R$  is less than 1.0 but greater than 0.4. It is suggested that  $L$  be in increments of 1.5m or 3m to facilitate fabrication, construction and inspection. Pipe diameter is usually not a factor but it is recommended that an 500mm minimum be used. It should be carefully noted that, generally, the economics favor slotted drain pipe inlets designed with carryover rather than for total flow interception. Make certain that there is a feasible location to which the carryover may be directed.

Determine the amount of carryover (C.O.) from Figure 4.18.

At on-grade inlets where carryover is not to be permitted,  $L_A$  must be at least the length of  $L_R$ .

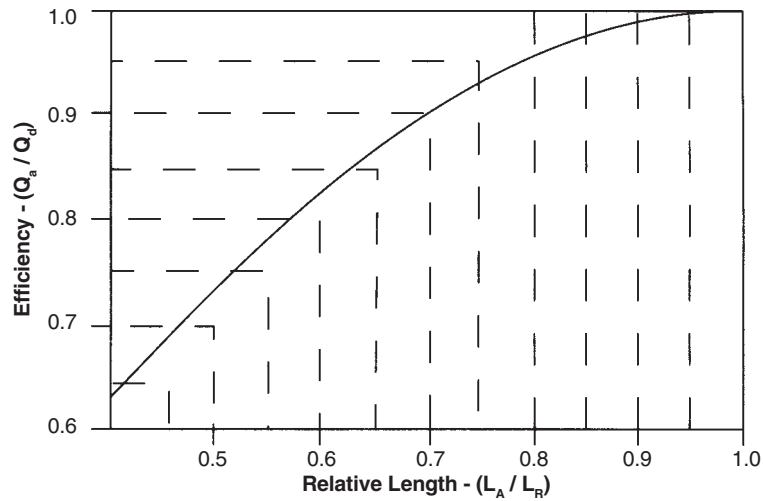

Example: if 20% carryover ( $Q_a / Q_d = 80\%$ ) is allowed, then only 58% ( $L_A / L_R$ ) of the total slotted drain length is required resulting in a 42% savings in material and installation costs.

Figure 4.18 Slotted drain carryover efficiency

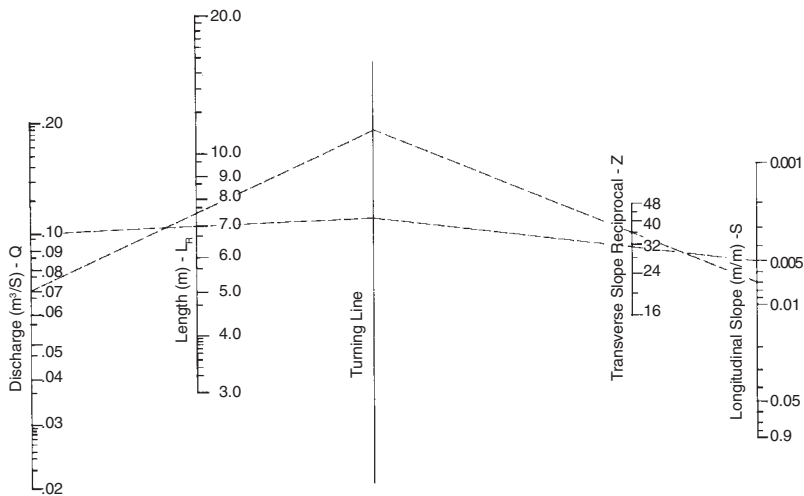

Figure 4.19 Slotted drain design Nomograph

At sag inlets, the required length of slotted drain,  $L_R$ , for total interception can be calculated from the following equation:

$$L_R = \frac{0.072 Q_D}{\sqrt{h}}$$

For sag inlets,  $L_A$  should be at least 2.0 times the calculated  $L_R$  to insure against the debris hazard.  $L_A$  should never be less than 6m for sag inlet cases.

The slot should be parallel to the curb and located in the gutter approximately as shown.

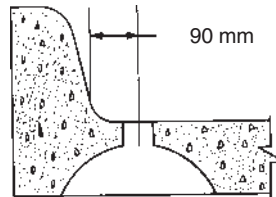

#### Definitions

- S — Longitudinal gutter or channel slope, m/m
- $S_x$  — Transverse slope, m/m
- Z — Transverse slope reciprocal, m/m
- d — Depth of flow, m
- L — Length of slot, m
- Q — Discharge, ( $m^3/s$ )
- $L_R$  — Length of slot required for total interception, m (No carryover)
- $L_A$  — An assumed length of slot, m
- $Q_d$  — Total discharge at an inlet, ( $m^3/s$ )
- $Q_a$  — An assumed discharge, ( $m^3/s$ )

Slotted Drain is used effectively to intercept runoff from wide, flat areas such as parking lots, highway medians — even tennis courts and airport loading ramps. In these installations, the drain is placed transverse to the direction of flow, so that the open slot acts as a weir intercepting all of the flow uniformly along the entire length of the drain. The water is not collected and channeled against a berm, as required by a slot-on-grade installation.

Slotted Drain has been tested for overland flow (sheet flow). These results are published.<sup>18</sup>

The tests included flows up to  $0.0011 m^3/s$  per metre of slot. The test system was designed to supply at least  $0.0007 m^3/s$  per metre which corresponds to a rainstorm of 380mm per hour over a 20m wide roadway (6 lanes). Slopes ranged from a longitudinal slope of 9 % and a Z of 16, to a longitudinal slope of 0.5% and a Z of 48. At the design discharge of  $0.0007 m^3/s$  per metre, it was reported that the total flow fell through the slot as a weir flow without hitting the curb side of the slot. Even at the maximum discharge of  $0.0011 m^3/s$  per metre and maximum slopes, nearly all the flow passed through the slot.

## REFERENCES

1. Davis, C. B., Sorenson, K. E., Handbook of Applied Hydraulics, 3rd Edition, 1969.
2. FHWA, Hydraulic Design of Highway Culverts, Hydraulic Design Series No. 5, Report No. FHWA-IP-85-15, Sept. 1985, Federal Highway Administration.
3. Design and Construction of Sanitary and Storm Sewers, Water and Pollution Control Federation Manual of Practice No. 9 and American Society of Civil Engineers Manuals and Reports on Engineering Practice No. 37, 1969.
4. Silberman, E., Dahlin, W.Q., Further Studies of Friction Factors for Corrugated Aluminum Pipes Flowing Full, Project Report No. 121, April 1971, University of Minnesota, St. Anthony Falls Hydraulic Laboratory, Minneapolis, MN.
5. Grace, J. L., Jr., Friction Factors for Hydraulic Design of Corrugated Metal Pipe, Dept. of Defense, U.S. Corps of Engineers, Proceedings of the Highway Research Board, U.S. Waterways Experimental Station, Vol. 44, 1965.
6. Webster, M. J. and Metcalf, L. R., Friction Factors in Corrugated Metal Pipe, Journal of the Hydraulic Division, American Society of Civil Engineers, Vol. 85, Sept. 1959, pp. 35-67.
7. Brater, E. F., King, H.W., Handbook of Hydraulics, 6th Edition, McGraw-Hill Book Company, 1976.
8. Chow, V. T., Open Channel Hydraulics, McGraw-Hill Book Company, 1959.
9. Marsalek, J., Head Losses at Selected Sewer Manholes, Environmental Hydraulics Section, Hydraulics Division, National Water Research Institute, Canada Centre for Inland Waters, July 1985.
10. Ackers, P., An Investigation of Head Losses at Sewer Manholes, Civil Engineering and Public Works Review, Vol. 54, No. 637, 1959 pp. 882-884 and 1033-1036.
11. Archer, B., Bettes, F. and Colyer, P. J., Head Losses and Air Entrainment at Surcharged Manholes, Report No. IT185, Hydraulics Research Station, Wallingford, 1978.
12. Black, R. G., Piggott, T. L., Head Losses at Two Pipe Stormwater Junction Chambers, Proceedings Second National Conference on Local Government Engineering, Brisbane, September 19-22, 1983, pp. 219-223.
13. deGrout, C. F., Boyd, M. J., Experimental Determination of Head Losses in Stormwater Systems, Proceedings Second National Conference on Local Government Engineering, Brisbane, September 19-22, 1983.
14. Hare, C. M., Magnitude of Hydraulic Losses at Junctions in Piped Drainage Systems, Civil Engineering Transactions, Institution of Civil Engineers, 1983, pp. 71-77.
15. Howarth, D. A. and Saul, A. J., Energy Loss Coefficients at Manholes, Proceedings 3rd International Conference on Urban Storm Drainage, Goteburg, June 4-8, 1984, pp. 127-136.
16. Wright, K. K., Urban Storm Drainage Criteria Manual, Volume I, Wright-McLaughlin Engineers, Denver, Colorado, 1969.
17. Marsalek, J., Road and Bridge Deck Drainage Systems, Ministry of Transportation and Communications, Research and Development Branch, Ontario, Canada, Nov. 1982.
18. FHWA, Vol. 4, Hydraulic Characteristics of Slotted Drain Inlets, Feb. 1980, Report No. FHWA-RD-79-106, Federal Highway Administration.

## BIBLIOGRAPHY

Handbook of Steel Drainage and Highway Construction Products, American Iron and Steel Institute, 1983.

73-3 Implementation Package for Slotted CMP Surface Drains, U.S. Dept. of Transportation, July 1973.

Jones, C. W., Design of Culverts.

Bauer, W. J., Determination of Manning's n for 14 ft. Corrugated Steel Pipe, April 1969, Bauer Engineering, Inc., Chicago, IL, 27 pp.

Debris Control Structures, Hydraulic Engineering Circular No. 9, Feb. 1964, Federal Highway Administration, U.S. Government Printing Office, Washington, D.C. 20402, 37 pp.

Design Charts for Open Channel Flow, Hydraulic Design Series No. 3, 1961, U.S. Bureau of Public Roads.

Harrison, L. S., Morris, J. C., Normann, J. M., and Johnson, F. L., Hydraulic Design of Improved Inlets for Culverts, Hydraulic Engineering Circular No. 13, Aug. 1972, Federal Highway Administration, Hydraulics Branch, HNG-31, Washington, D.C. 20590.

Silberman, E., Effects of Helix Angle on Flow in Corrugated Pipes, Journal of the Hydraulics Division, American Society of Civil Engineers, Vol. 96, Nov. 1970, pp. 2253-2263.

Normann, J. M., Hydraulic Design of Large Structural Plate Corrugated Metal Culverts, Unpublished Report, Jan. 1974, Hydraulics Branch, Bridge Division, Office of Engineering, Federal Highway Administration, Washington, D.C. 20590, 17 pp.