



CORRUGATED STEEL PIPE INSTITUTE

Reline Procedure for Small Diameter Culverts Using Corrugated Steel Pipe

(For reline of culvert pipes 1000 mm Diameter and Smaller)

Replacing deteriorated culverts and storm sewers under a heavily traveled roadway or deep fill can be an expensive and disruptive operation. The detouring of traffic required for conventional reconstruction can create significant costs and public inconvenience. Relining with corrugated steel pipe will minimize project cost and time. Access is restricted in smaller diameter pipes so all cleaning, pipe insertion, coupling and grouting is done from the pipe ends or access points. Long lengths of strong, rigid, securely coupled CSP are ideal for this procedure. Designed to carry the full load above the pipe the total wall thickness of CSP remains relatively thin to optimize effective end area for maximum flow capacity.



Culvert Silted with De-Icing Salt & Sand

**Polymer Laminated CSP Reline Pipe
Fully Grouted**



Procedure

The following are suggestions only to assist qualified engineers and contractors in developing a construction plan. Each project is unique and will benefit from local experience and expertise.

1. Survey the existing host pipe noting unusual inward projections, deflections and damage. Take measurements to determine the largest liner size that will fit inside the host pipe allowing room for outside diameter of liner pipe, slide rails and approximately 50mm minimum grout space all around. Review the external working area, noting obstructions that may limit pipe lengths, equipment size, access and material storage.
2. Review the flow characteristics of the reduced diameter liner pipe and ensure that hydraulic requirements will be met. CSP is available in a variety of corrugations to meet both smoothness (Manning n value) and structural requirements

3. Drain the water and clear the host pipe of silt and debris removing any obvious obstructions. Water needs to be controlled with cofferdams, pumps, and piping as appropriate. Insure that all environmental requirements are met.
4. If a small diameter culvert or sewer requires relining due to a change in environmental conditions such as an increased aggressiveness due to road salts, the Engineer should consider using a Polymer Laminated CSP which can provide a 100 year add-on to the standard service life of a CSP. See the CSPI Technical Bulletin for more information on Polymer Laminated CSP.
5. The corrugated steel liner pipe should be ordered. Specify inside diameter (allow for steel thickness and wall thickness due to corrugation), steel thickness (to carry full load), corrugation profile (for strength and hydraulics), pipe length (for access and fewest joints), coating type (for site conditions and durability) and coupler type (for pull apart strength and grout exclusion).
6. The host pipe must be made ready for lining. This includes cleaning, usually by pressure wash and pumping. The invert may be smooth enough and on grade allowing the liner to slide directly on the surface. In many cases, it will be necessary to install lubricated slide rails (wood, steel or plastic lumber) along the invert. With badly deteriorated inverts, a pre pour of grout will establish a level, sliding surface.
7. Grout access holes must be cut in the top of the host pipe at least 500mm in from both ends and may be augured with drop tubes from the surface at intervals on longer projects.
8. In some cases sliding shoes for grade setting may be attached with steel strapping to the liner pipe prior to insertion. As pipes will float during grouting, blocks or standoffs should be attached to the outside top of the liner to limit movement. If grade is not a concern the CSP liner can be allowed to rise without blocks, to touch the host pipe. The corrugations allow the grout to flow over the liner.
9. Liner CSP can be either pulled using cables or pushed into place. As pipes are joined outside of the host pipe, insertion is from one end only. CSP ends should be protected to prevent damage from pushing equipment. Insertion is interrupted when the liner is about one metre from the end of the host pipe to allow coupling of the next liner section.
10. Strong, grout tight external couplers are critical to the success of these projects. Several designs are available that incorporate corrugations that fully seat into the re-corrugated ends of the CSP to resist pull or push apart forces. In some cases the external fastening hardware, on a coupler will impede insertion. The preferred coupler is the Rod & Lug or alternatively heavy-duty steel industrial strapping that can be used to close and secure the corrugated coupler bands without reducing clearance. Self-drilling / self-tapping screws are then used to further secure the band to the liner.

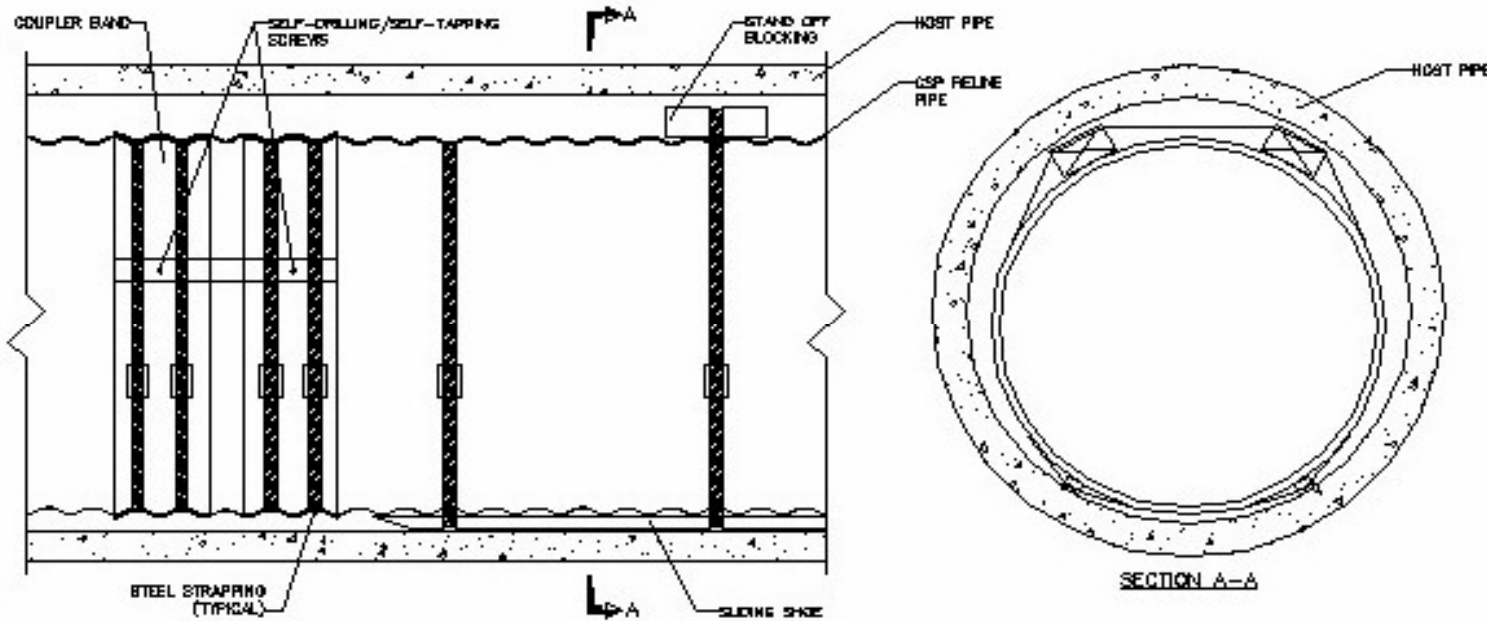

COUPLER BAND, STEEL STRAPPING, SLIDING SHOE AND STAND OFF BLOCKING



**JACKING CORRUGATED STEEL PIPE INTO CONCRETE PIPE
HIGH FILL REPAIR SITUATION**

11. Before the liner can be grouted, bulkheads between the liner and host need to be built at both ends. If the host is severely damaged or severed it will need to be reinforced to contain the grout. Bulkheads are typically constructed with hand placed and finished concrete.
12. A properly designed lean grout is poured or pumped through the openings, on the top of the host pipe. The grout flows by gravity, filling the space between the host pipe and CSP liner. Grout also fills any external voids if the host is perforated. Progress can be monitored at the grout openings. The downstream opening must be sealed with a sandbag when the grout reaches it. Grouting is complete when the up-stream grout opening is full.



**Free Flowing
Lean Grout**

**Compressive
Strength**

1380 kPa (200 psi)

050402

CORRUGATED STEEL PIPE INSTITUTE

652 Bishop St., Unit 2A
Cambridge, Ontario N3H 4V6
Phone: 866-295-2416 • Fax: (519) 650-8081
Email us at: info@cspi.ca
Visit our web site at www.cspi.ca